

Bridge Abutment Design

Doug Parmerlee, PE

Department Manager, Bridge Design, Michigan

LRFD Compared with ASD

- LRFD is supposed to be a more rational method imposing larger load factors on variable loads (such as live load) and smaller load factors on loads which are well defined (such as dead load).
- ASD treated all loads equally.
- LRFD seems to impose higher horizontal pressures as compared with the ASD methodology.
- Pile driving vibrations seem to be more pronounced with LRFD.
- Increase in foundation costs with LRFD.

DESIGN PHILOSOPHY

- General Equation – $\sum \eta_i \gamma_i Q_i \leq \phi R_n = R_r$ (LRFD 1.3.2)
- η_D = Ductility Load Modifier (LRFD 1.3.3)
- η_R = Redundancy Load Modifier (LRFD 1.3.4)
- η_I = Operational Importance Load Modifier (LRFD 1.3.5)
- γ_i = Load Factor (LRFD 3.4)
- Q_i = Force Effect (LRFD 3.5+)
- ϕ = Resistance Factor
- R_n = Nominal Resistance
- R_r = Factored Resistance

LOADS

- Superstructure dead load (DC)
 - Divide dead load reaction by length of abutment not including turned back wingwalls.
- Superstructure live loads (LL)
 - Due to load sharing characteristics of a solid wall, do not use live load beam end reactions.
 - Divide live load reaction by length of abutment not including turned back wingwalls.
- Wall dead load (DC)
- Backfill over heel (EV)
- Horizontal earth pressure (EH)
 - Could have a horizontal and vertical component for $\beta \neq 0$.

LOADS

- Thermal forces from superstructure (TU)
 - Usually from shear deformation of elastomeric bearings
- Braking forces from superstructure (BR)
- Wind on live load on superstructure (WL)
- Wind on structure (WS)
- Live load surcharge (LS)

Table 3.11.6.4-1—Equivalent Height of Soil for Vehicular Loading on Abutments Perpendicular to Traffic

Abutment Height (ft)	h_{eq} (ft)
5.0	4.0
10.0	3.0
≥ 20.0	2.0

LIVE LOAD SURCHARGE (LS)

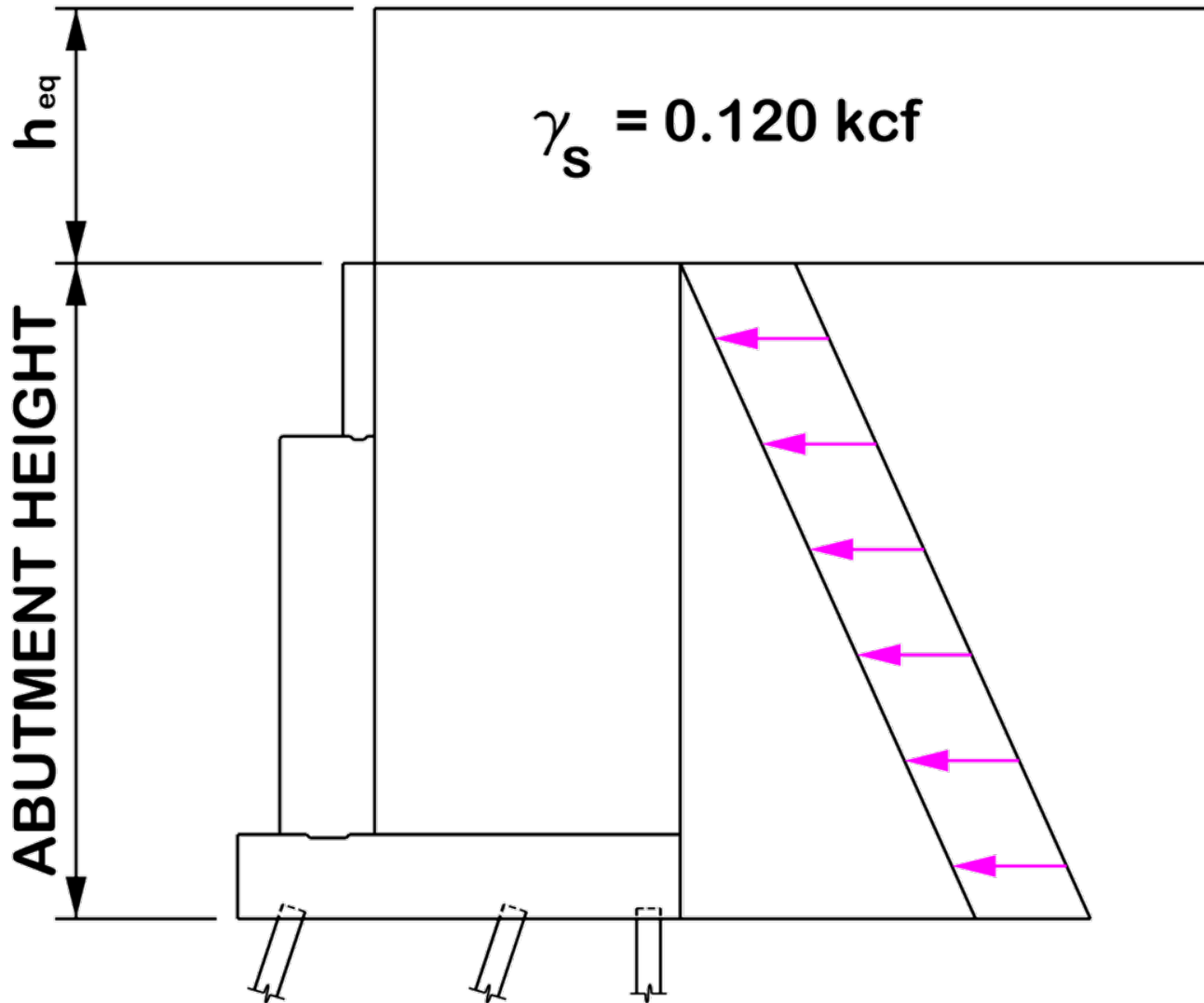

LIVE LOAD SURCHARGE (LS)

EPS Backfill

- Much lighter than sand backfill.
- Induces virtually no horizontal pressures on abutment (Prudent to design for some amount of horizontal pressure).
- Requires a PVC liner to protect it from petroleum spills.
- Requires a concrete cap slab to distribute traffic loads.
- More expensive than sand backfill, but could cause other cost savings.

EPS LOADING DIAGRAM

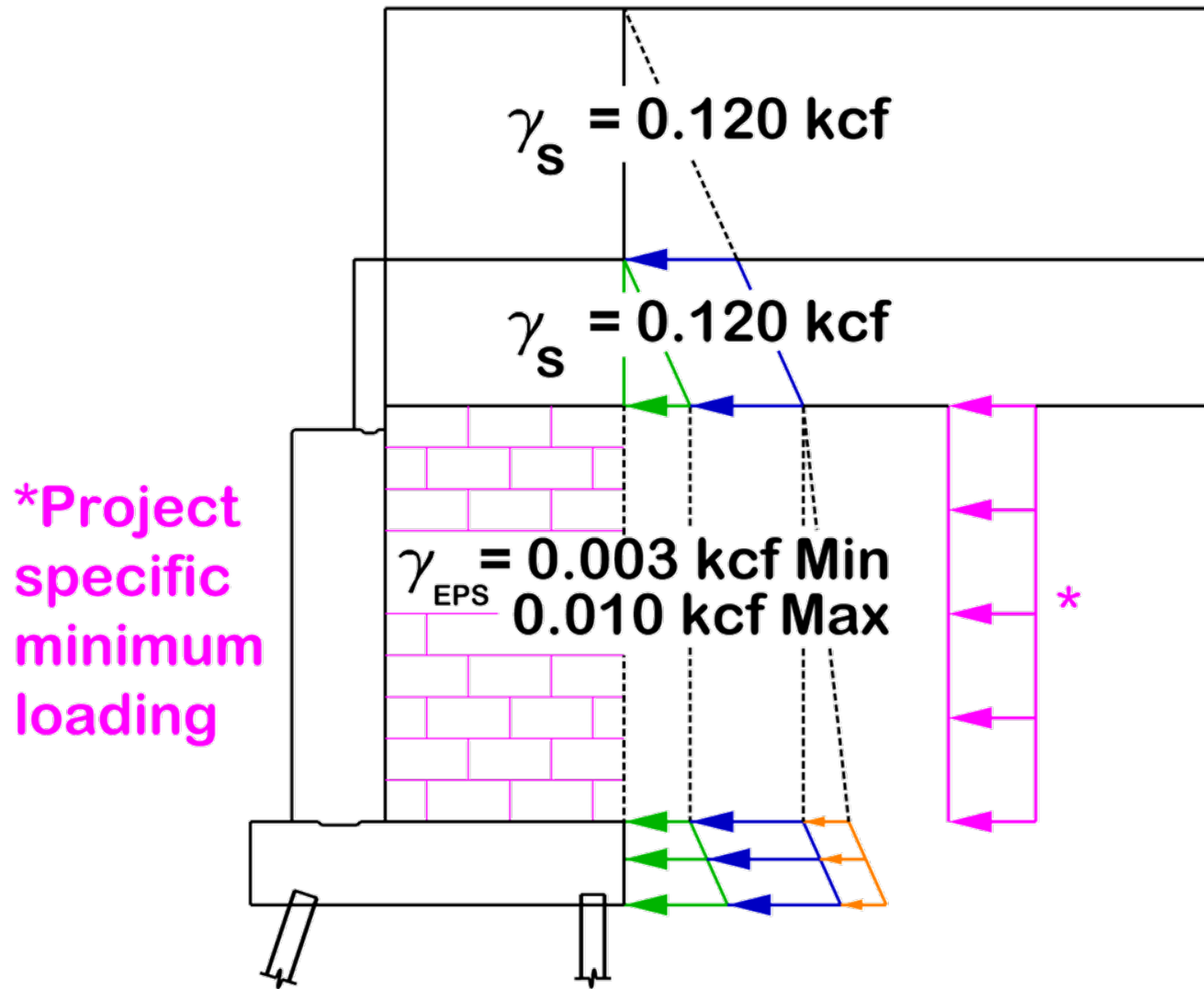

EPS LOADING DIAGRAM

LOAD CASES AND COMINATIONS

- Load Cases described in the MDOT Bridge Design Manual section 7.03.01.
- LRFD Load Combination Limit States (LRFD 3.4).
- Abutment Loading also discussed in LRFD 11.5.
- I came up with are a minimum of 30 combinations.
- Need more combinations for flooding, scour, seismic, vehicle collision on retaining walls.

7.03.01

Abutment Design

A. Design Cases

The following cases must be considered in the design of an abutment:

Case I

Construction state: abutment built and backfilled to grade.

Case II

Bridge open to traffic with traffic loading on the approach only.

Case III

Bridge with traffic on it and no load on approach.

Case IV

Contraction: Loading forces of Case II plus the effects of temperature contraction in the deck transmitted to the abutment. Tim.

Expansion: For integral abutments Case IV instead assumes the loading forces of Case III with the addition of an expansion force transmitted from the deck. (8-20-2009)

LOAD CASES AND COMBINATIONS

- One of the principles of LRFD is to combine loads to cause the most severe force effects.
- Permanent loads have variable load factors
- Using minimum load factor for some loads may produce more severe force effects on certain components.
- Load combination naming convention:
 - “A” intended to produce maximum toe bearing values.
 - “A2” intended to produce maximum heel bearing values.
 - “B” intended to produce minimum horizontal resistance and maximum eccentricity.

LOAD COMBINATIONS

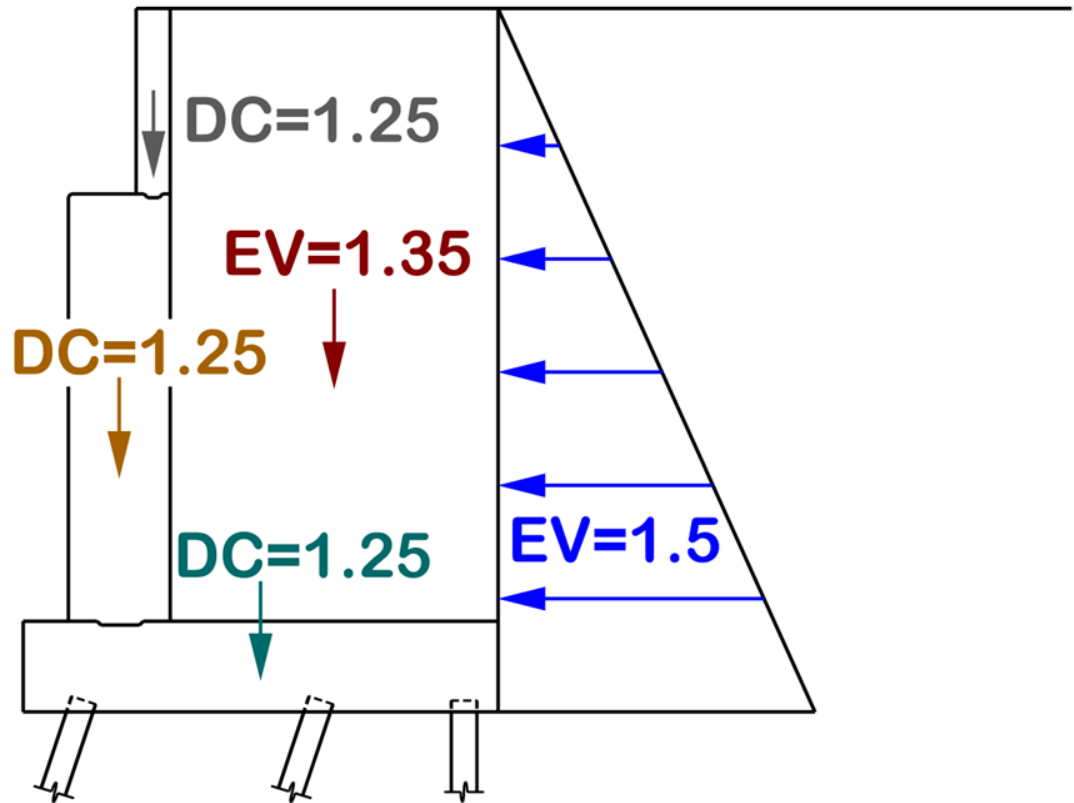
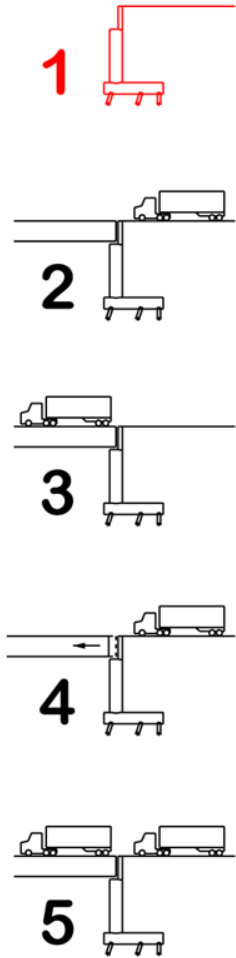

CASE 1 STRENGTH IA

LOAD COMBINATIONS

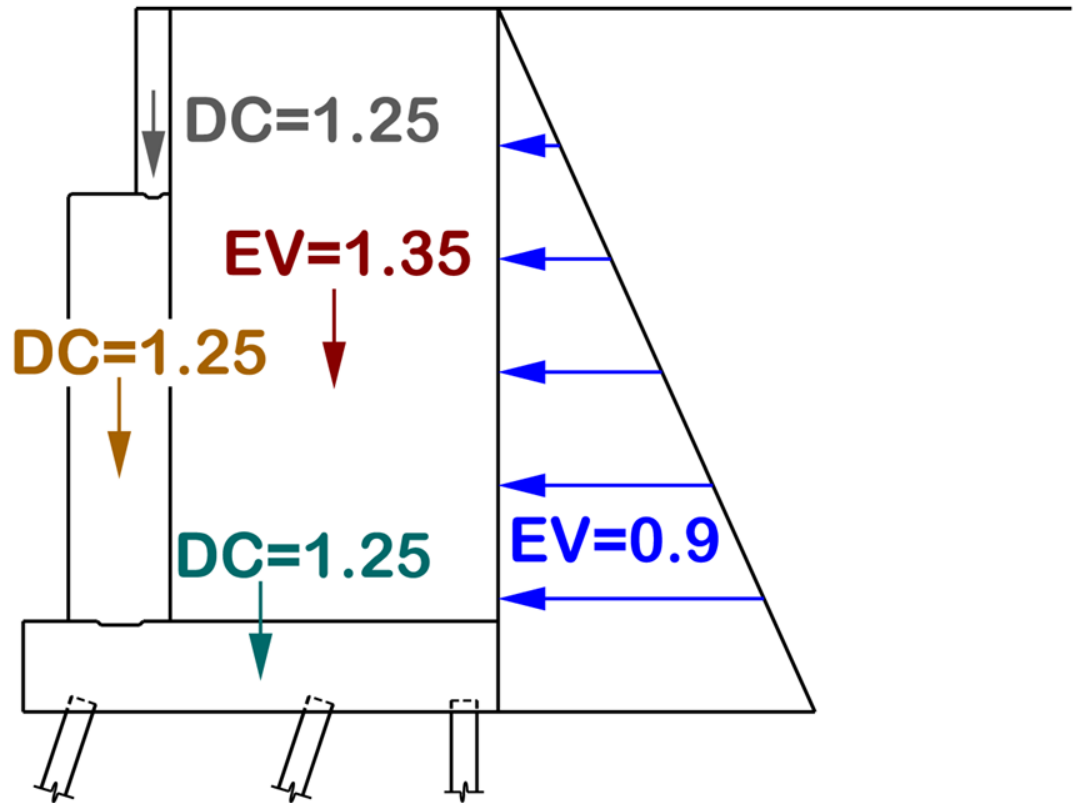
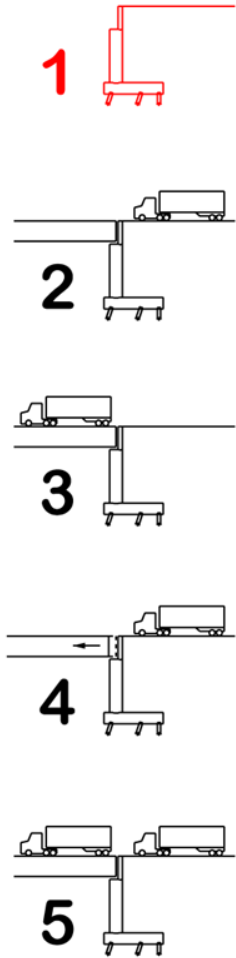

CASE 1 STRENGTH IA2

LOAD COMBINATIONS

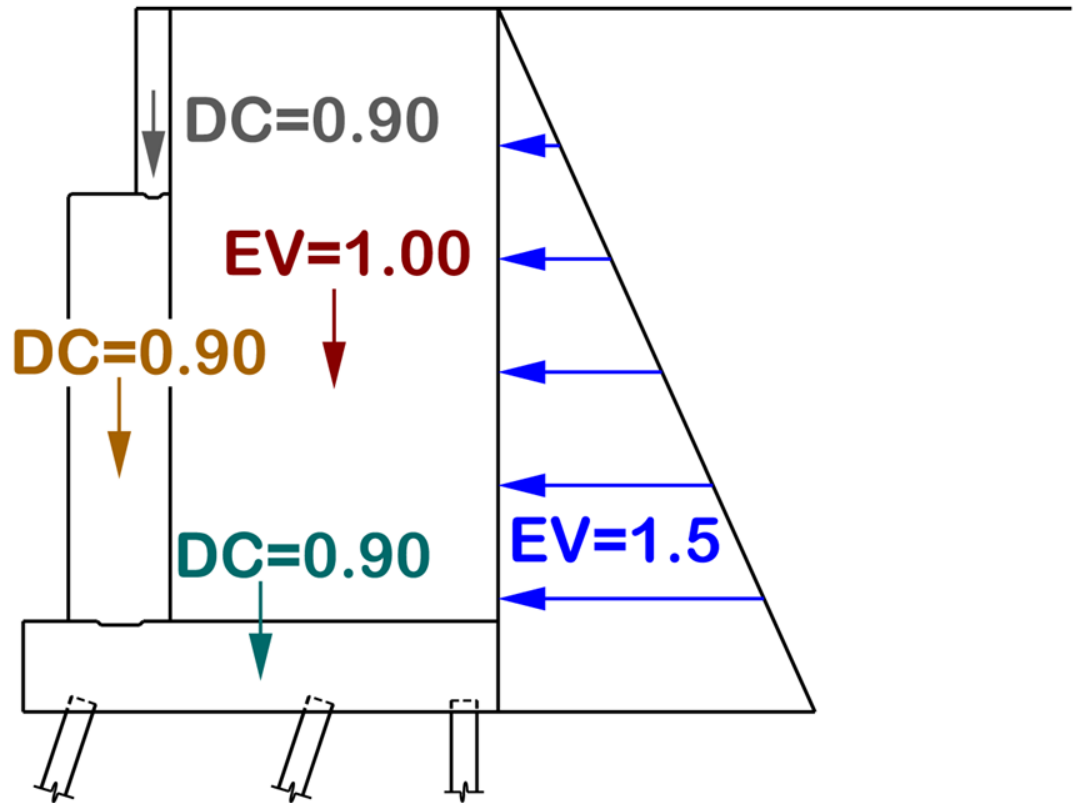
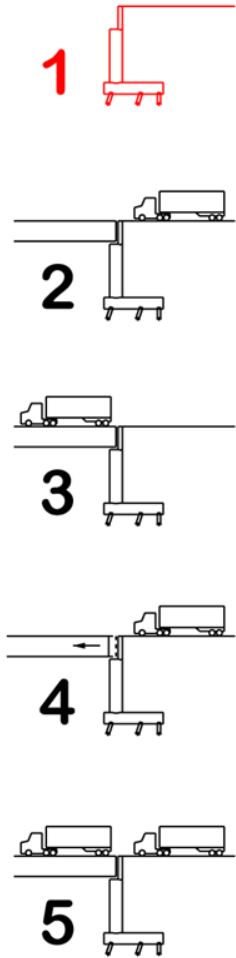

CASE 1 STRENGTH IB

LOAD COMBINATIONS

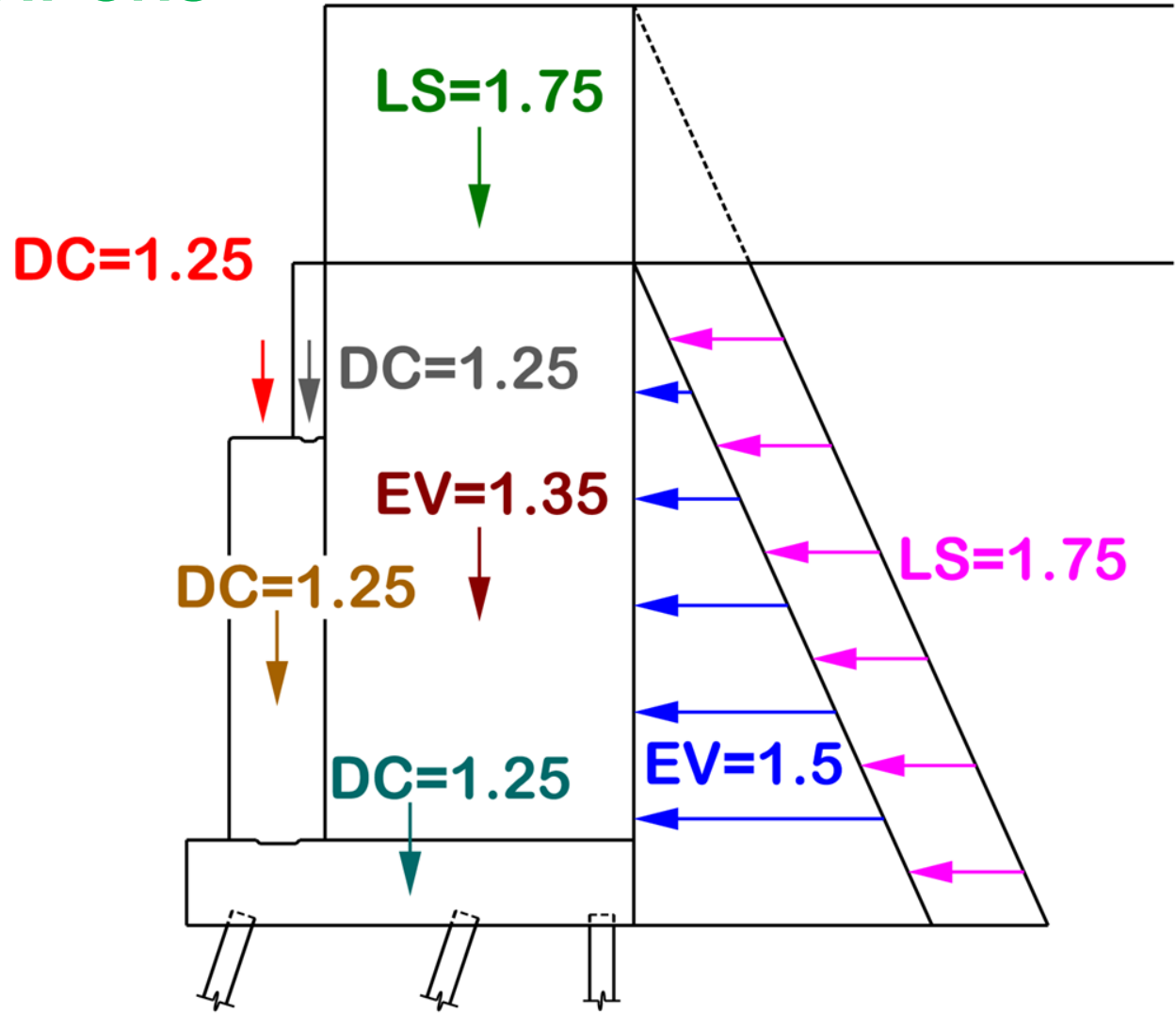
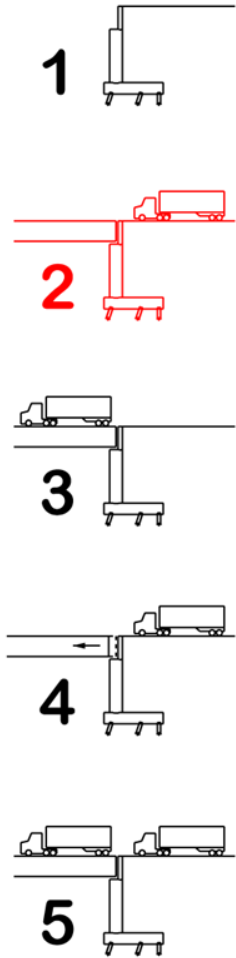

CASE 2 STRENGTH IA

LOAD COMBINATIONS

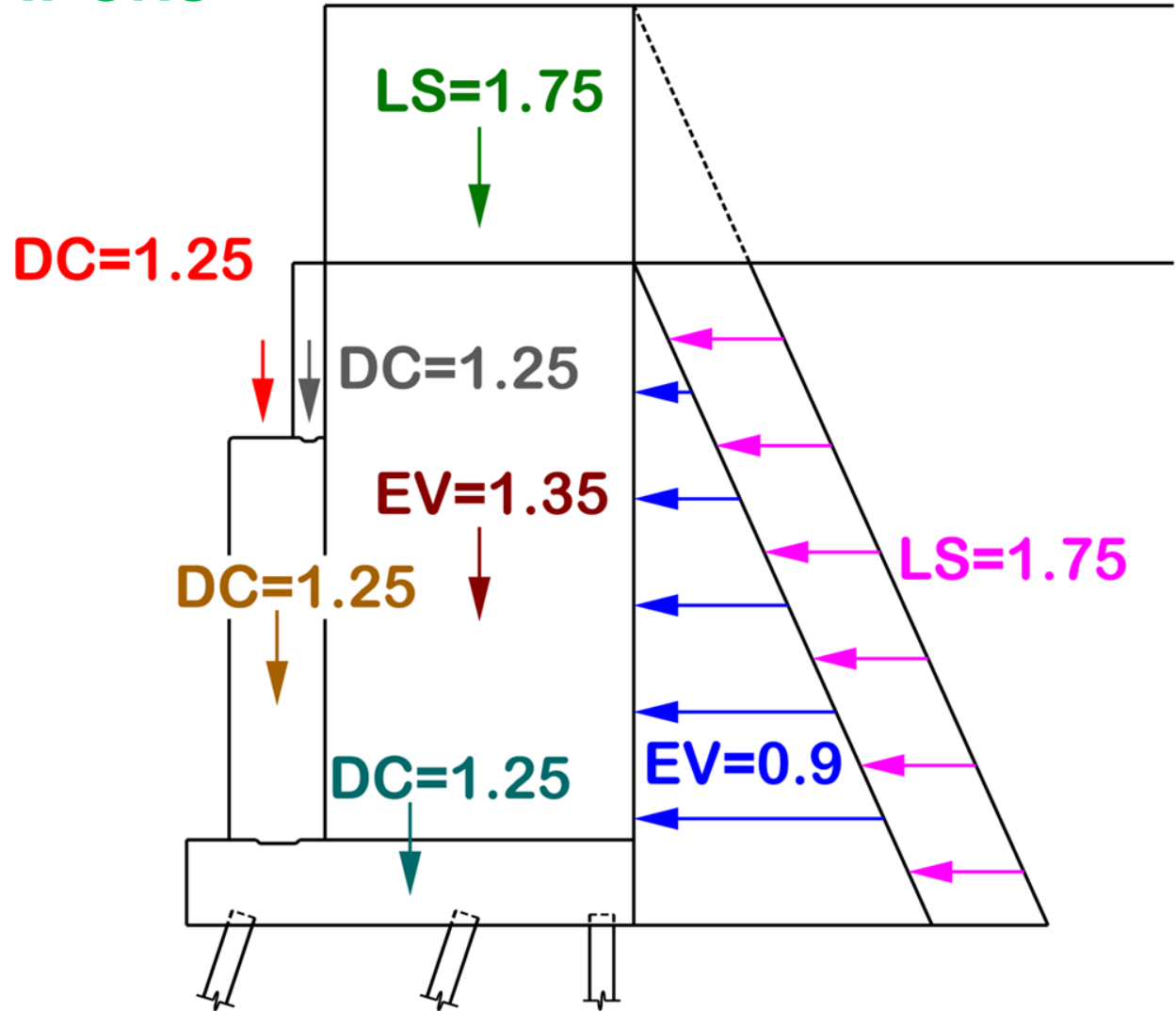
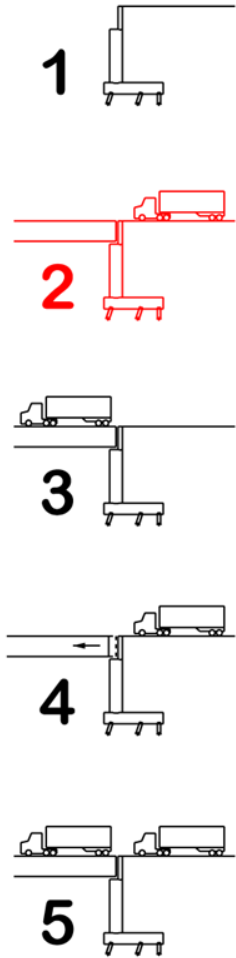

CASE 2 STRENGTH IA2

LOAD COMBINATIONS

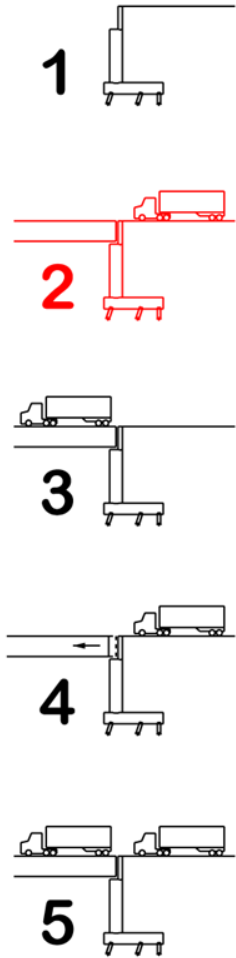

DC=0.90

DC=0.90

DC=0.90

DC=0.90

EV=1.00

EV=1.5

LS=1.75

LS=1.75

CASE 2 STRENGTH IB

LOAD COMBINATIONS

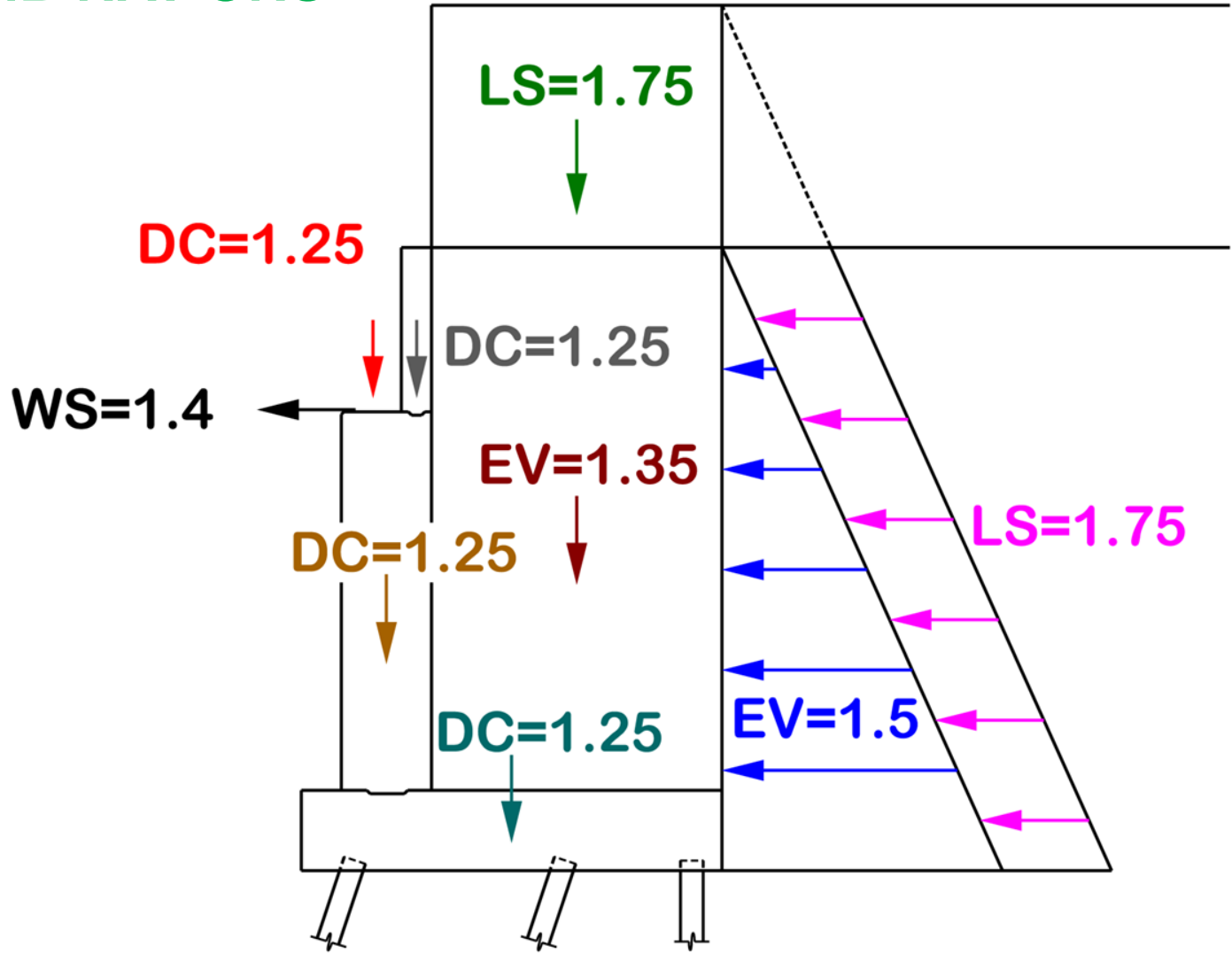
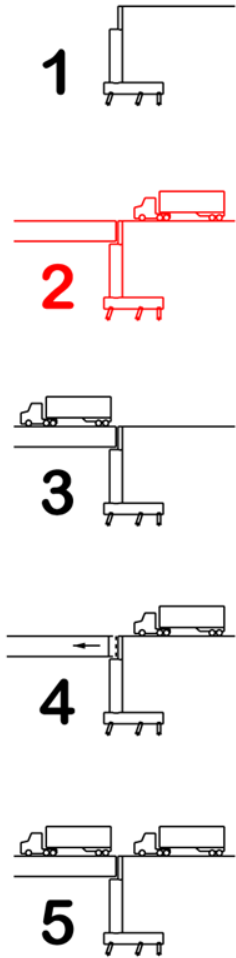

CASE 2 STRENGTH IIIA

LOAD COMBINATIONS

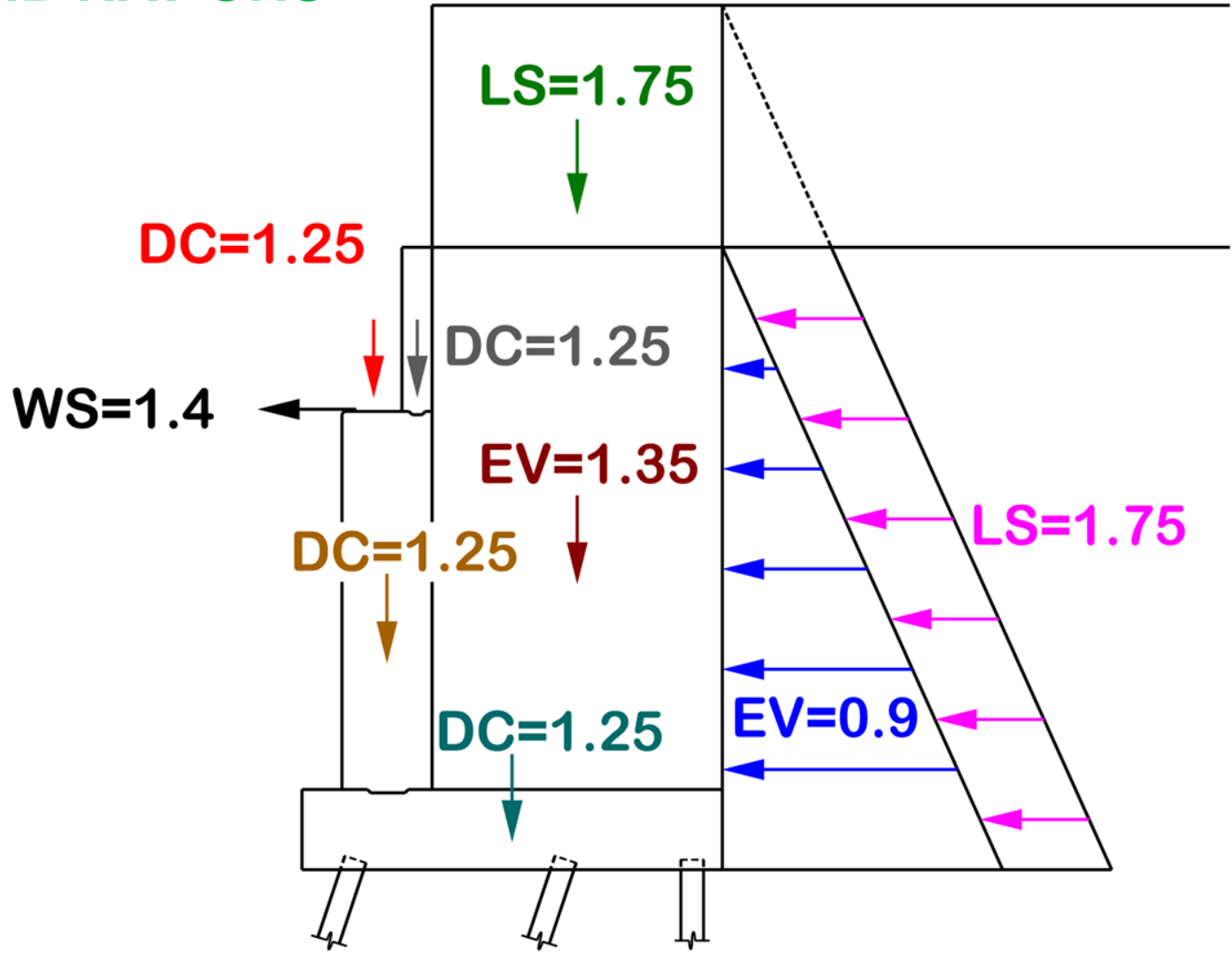
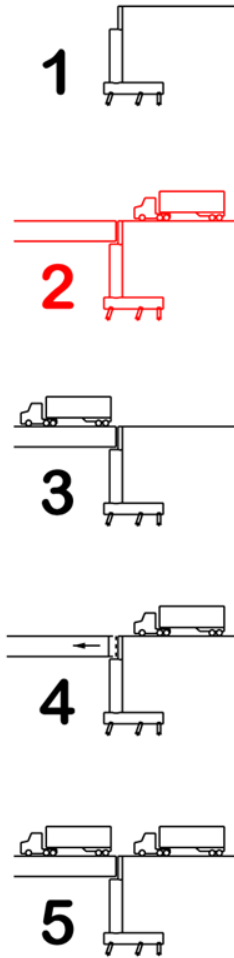

CASE 2 STRENGTH IIIA2

LOAD COMBINATIONS

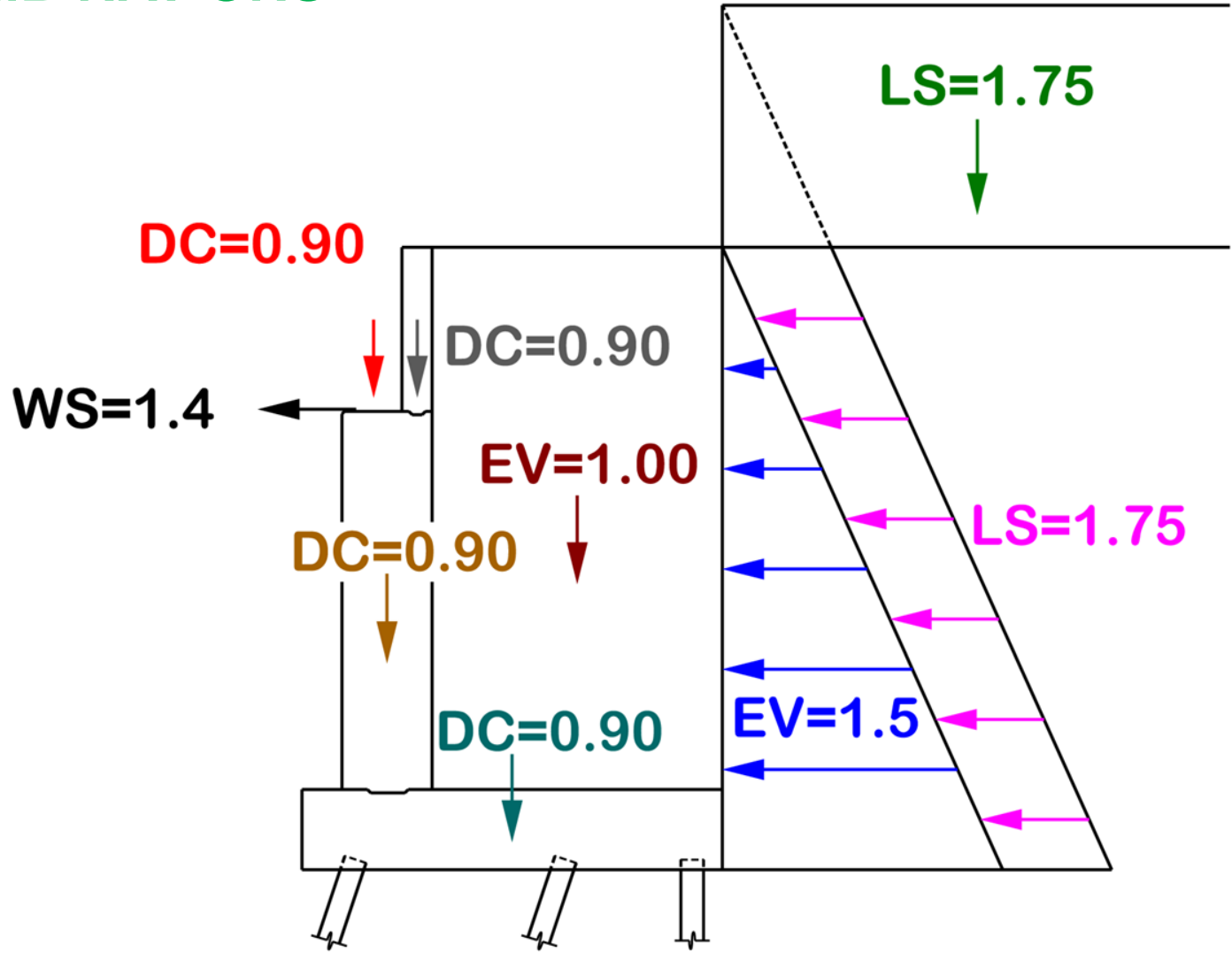
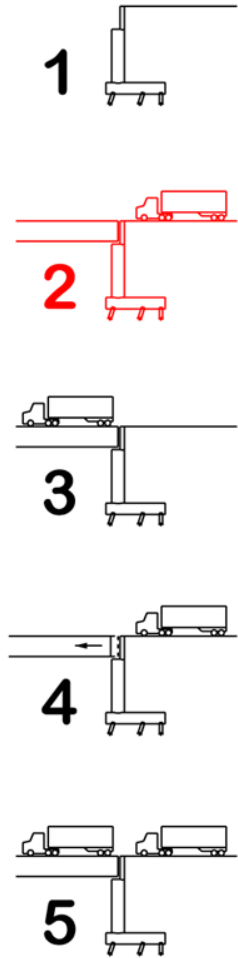

CASE 2 STRENGTH IIIB

LOAD COMBINATIONS

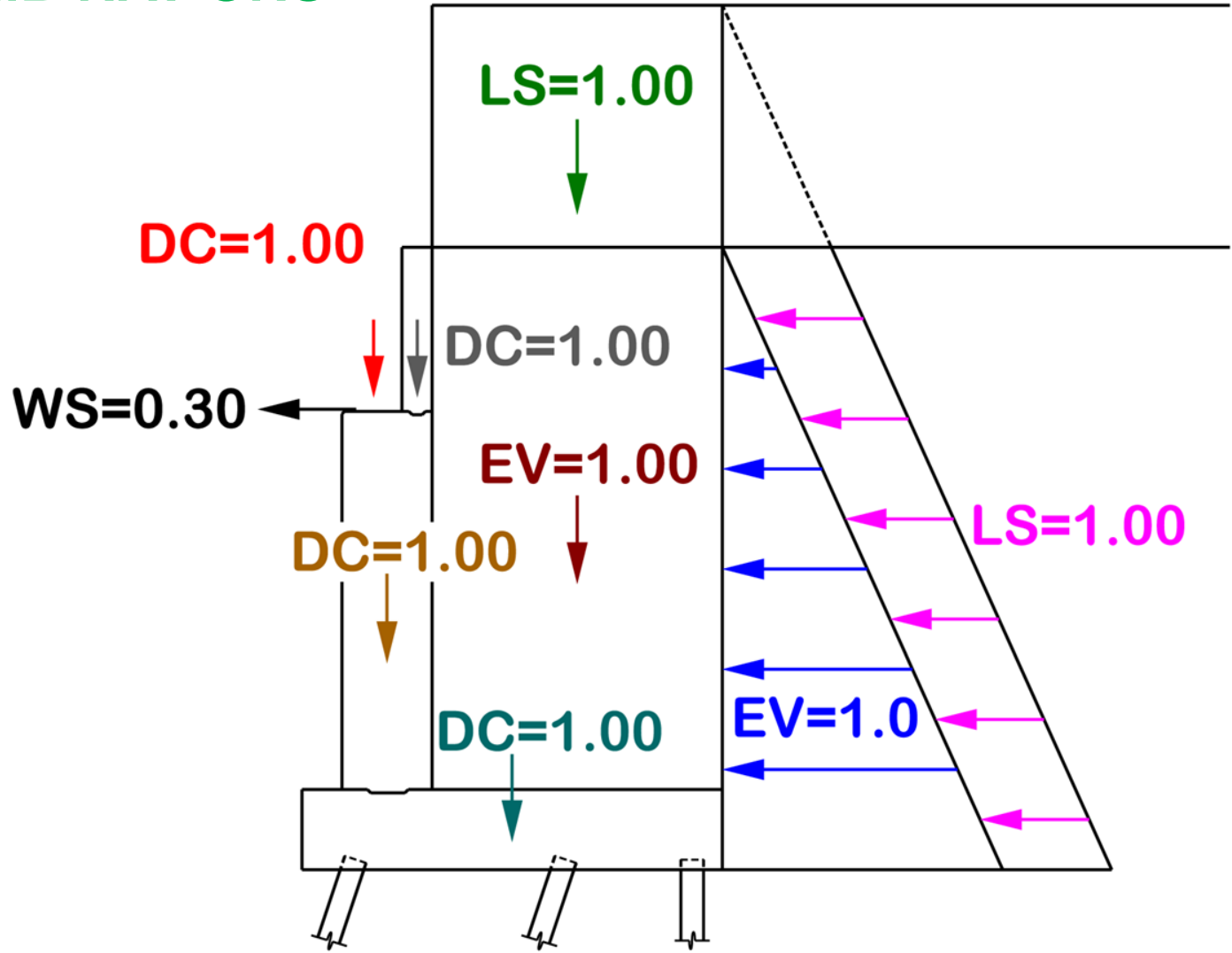
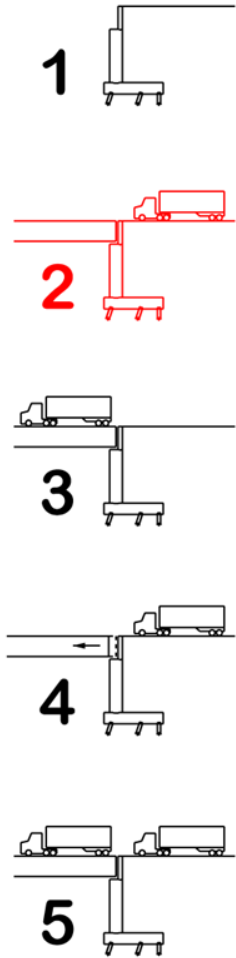

CASE 2 SERVICE I

LOAD COMBINATIONS

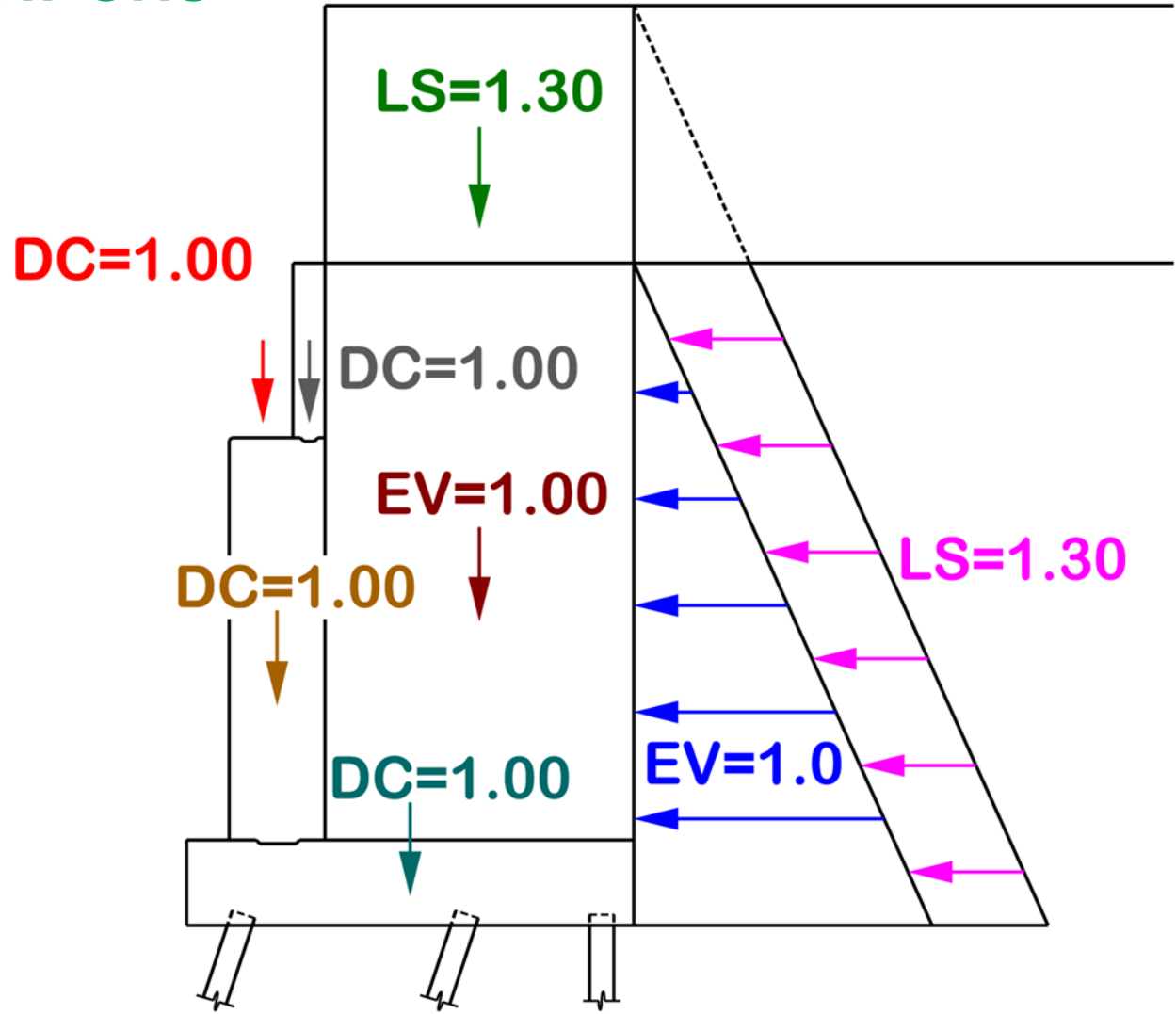
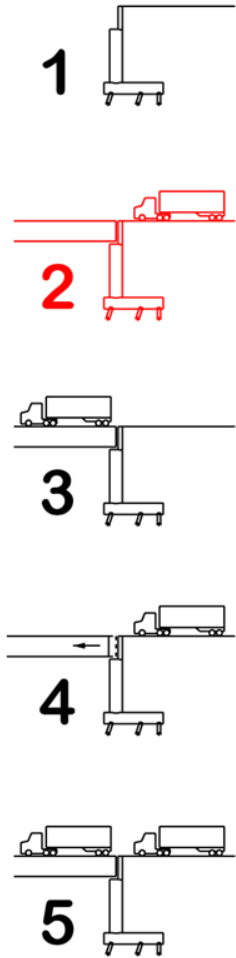

CASE 2 SERVICE II

LOAD COMBINATIONS

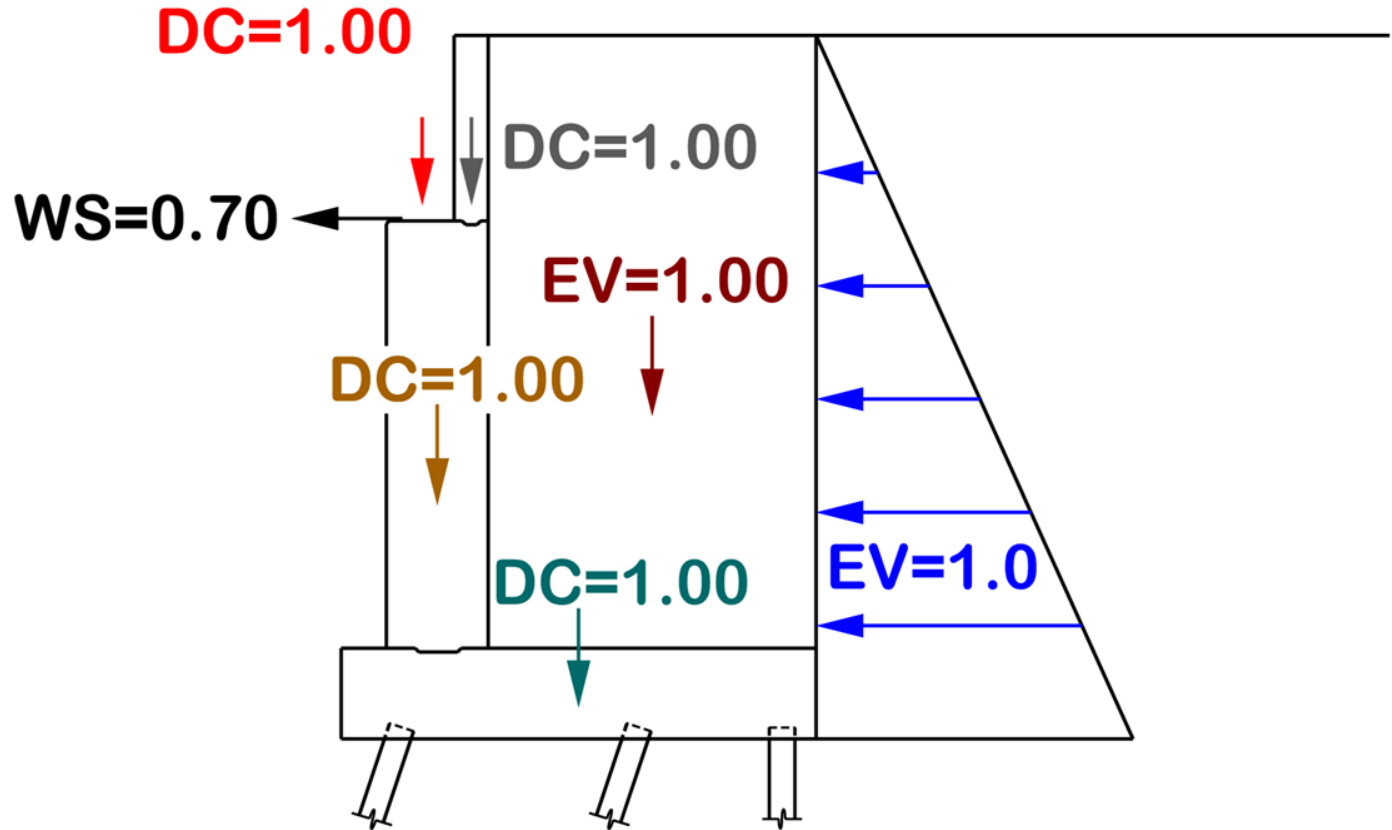
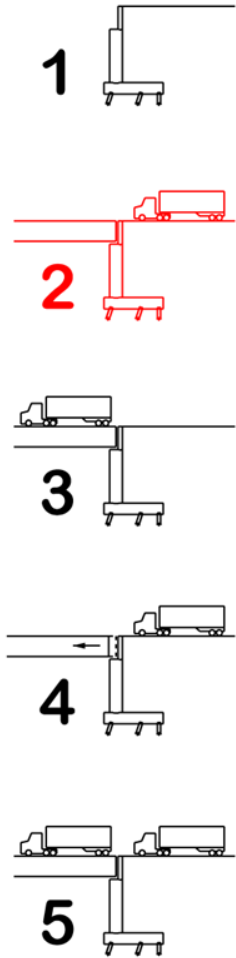

CASE 2 SERVICE IV

LOAD COMBINATIONS

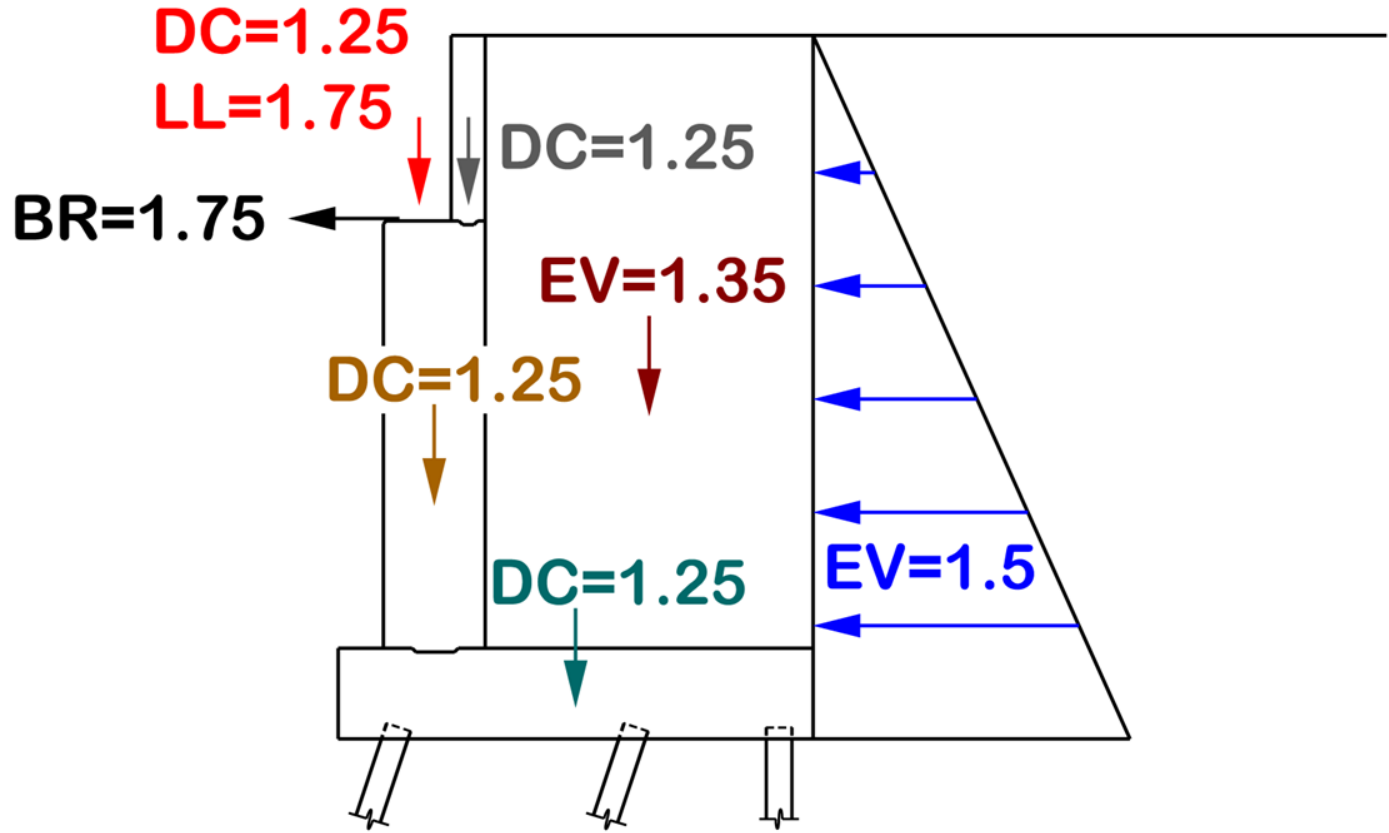
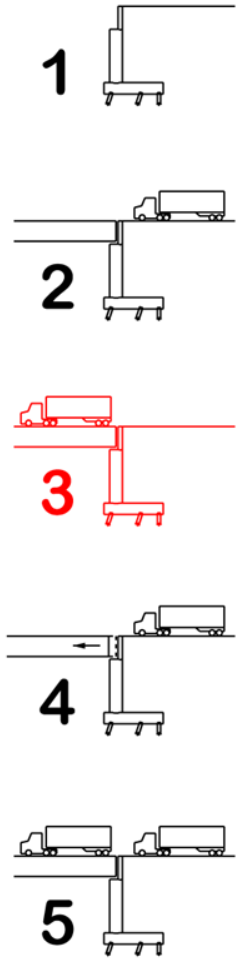

CASE 3 STRENGTH IA

LOAD COMBINATIONS

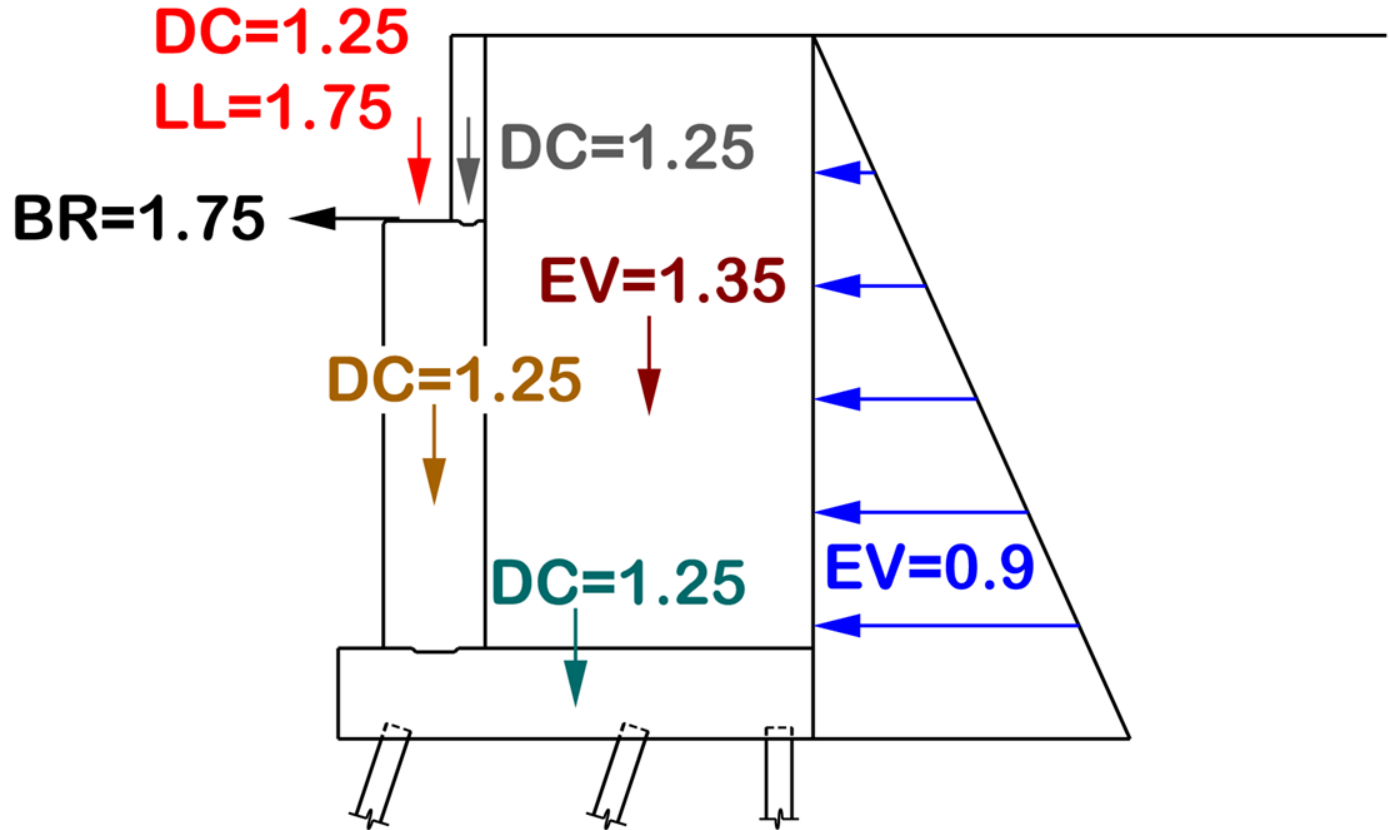
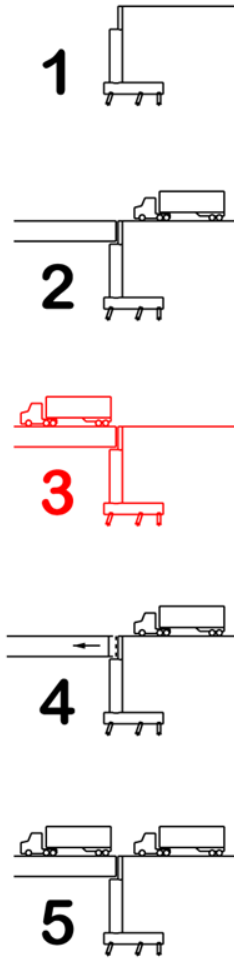

CASE 3 STRENGTH IA2

LOAD COMBINATIONS

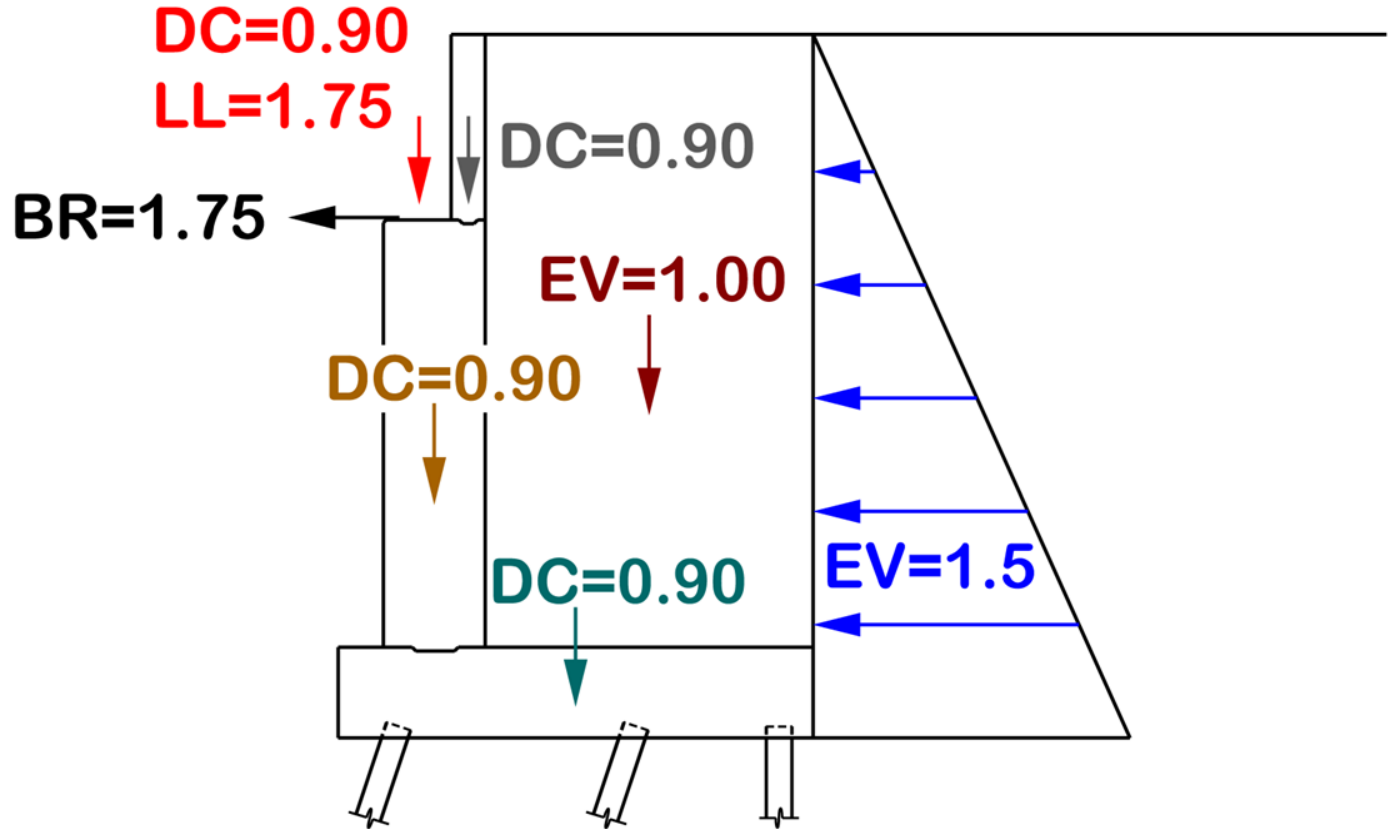
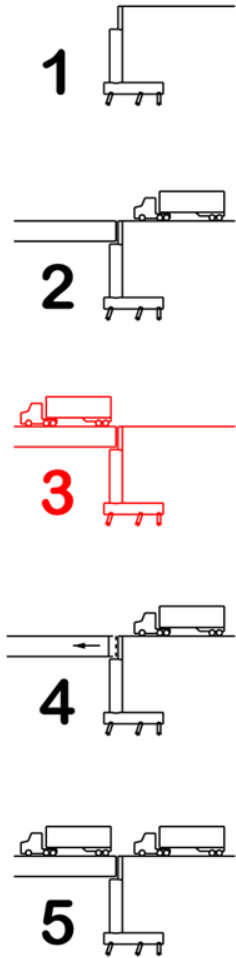

CASE 3 STRENGTH IB

LOAD COMBINATIONS

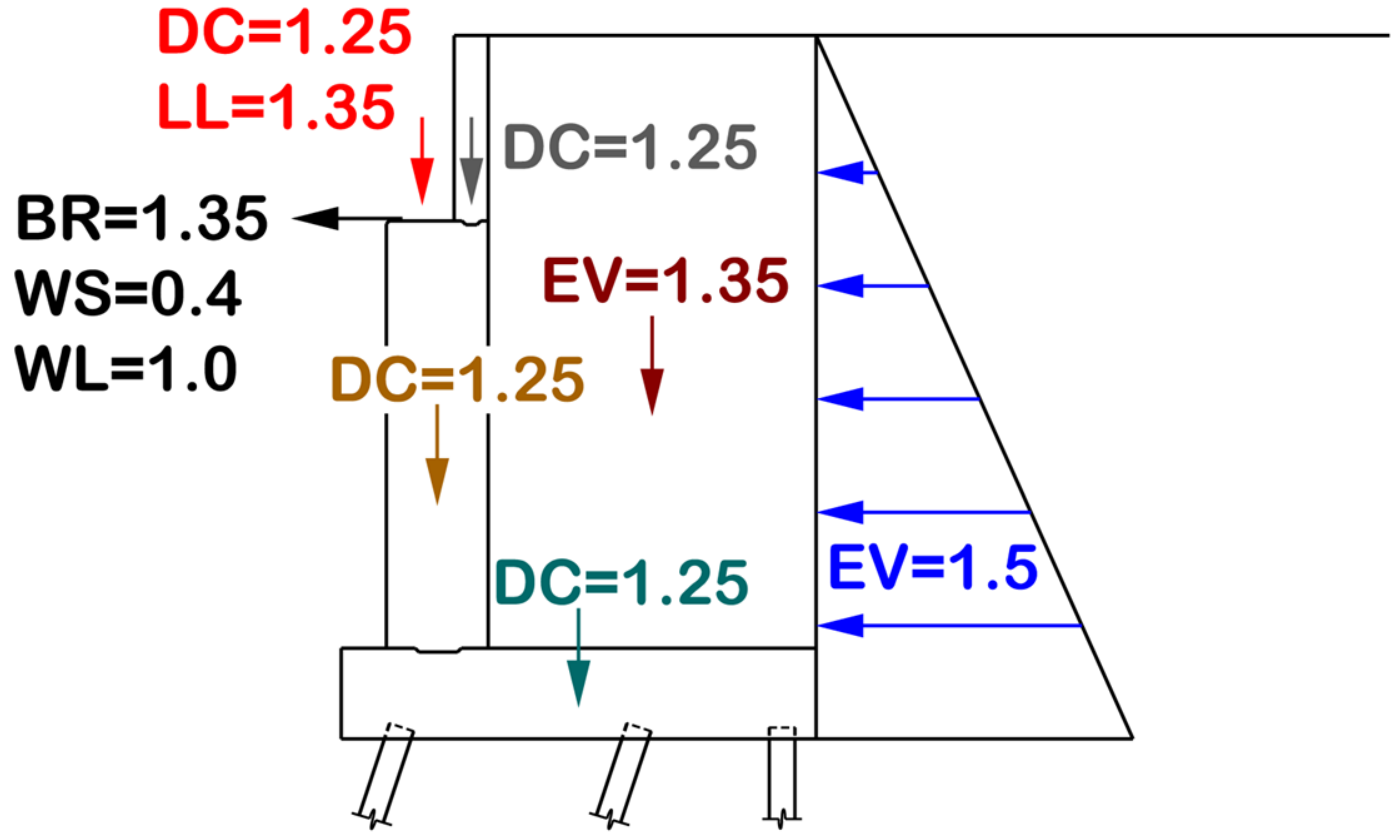
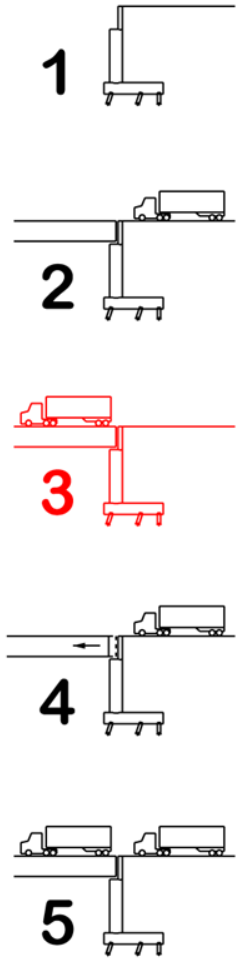

CASE 3 STRENGTH VA

LOAD COMBINATIONS

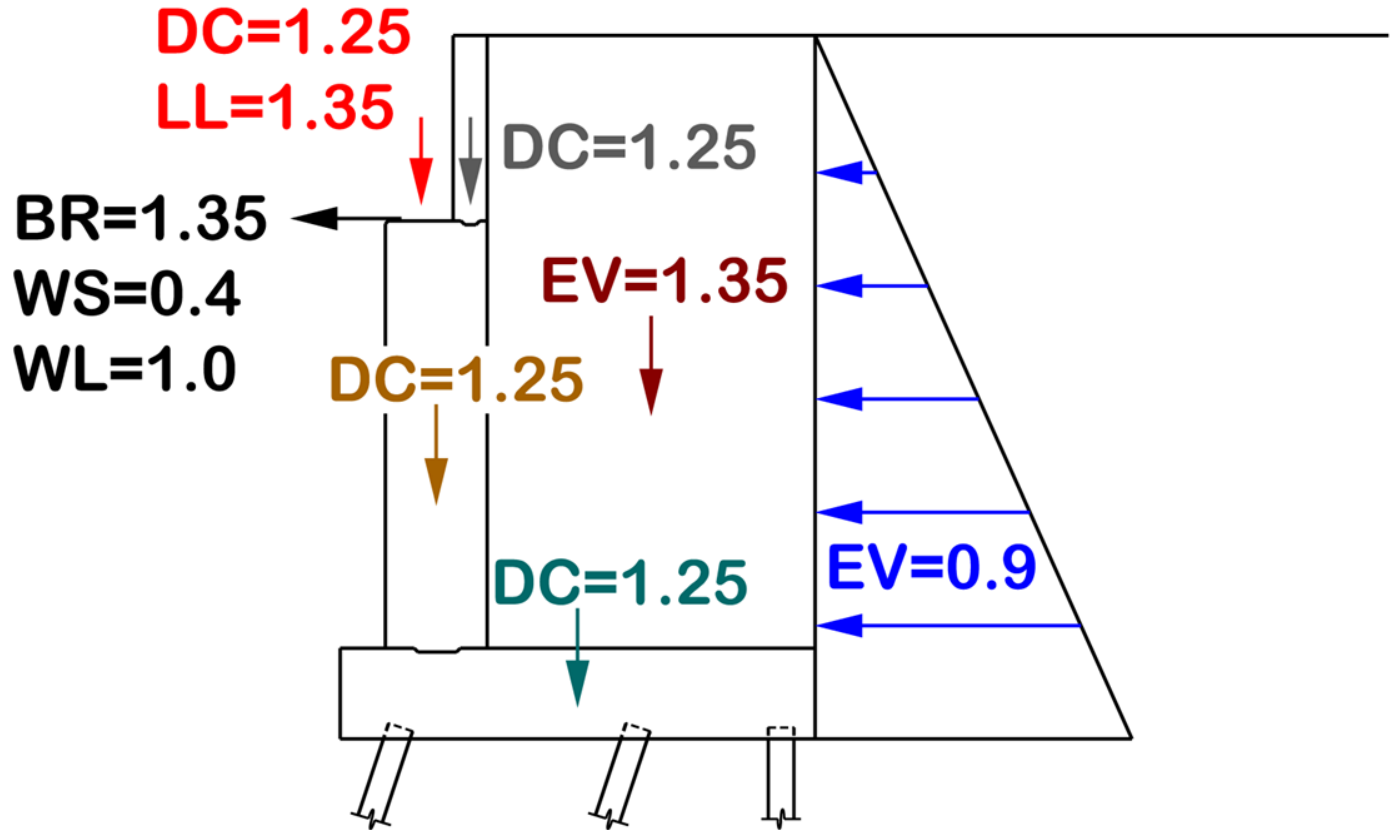
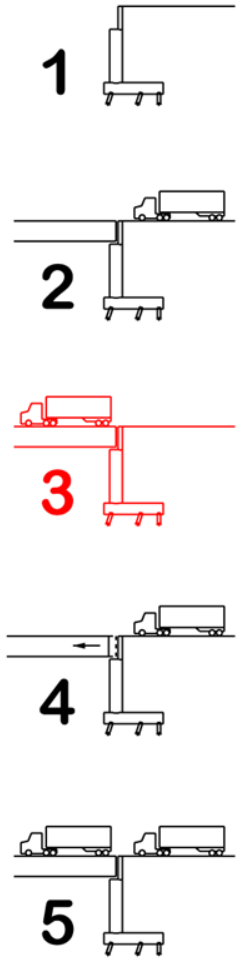

CASE 3 STRENGTH VA2

LOAD COMBINATIONS

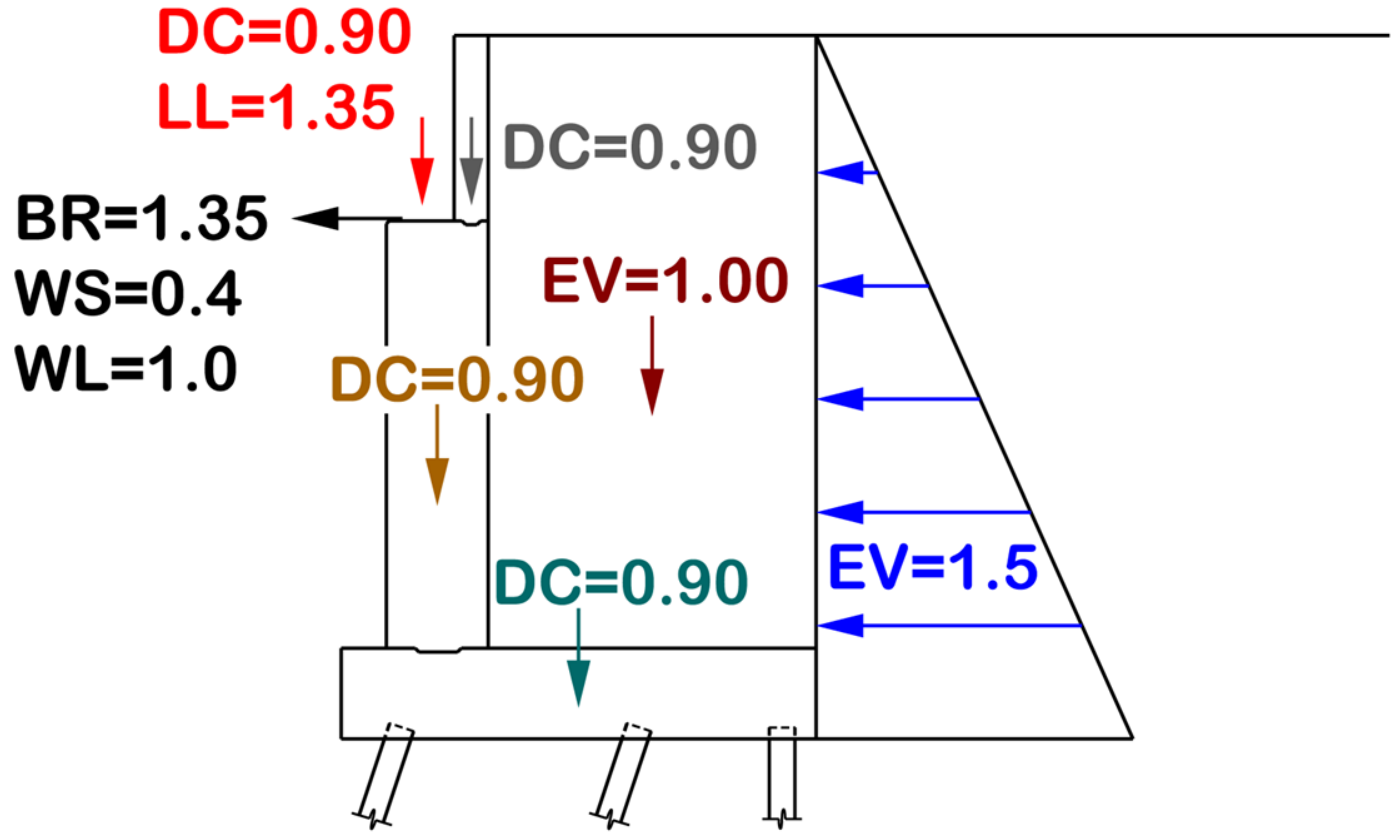
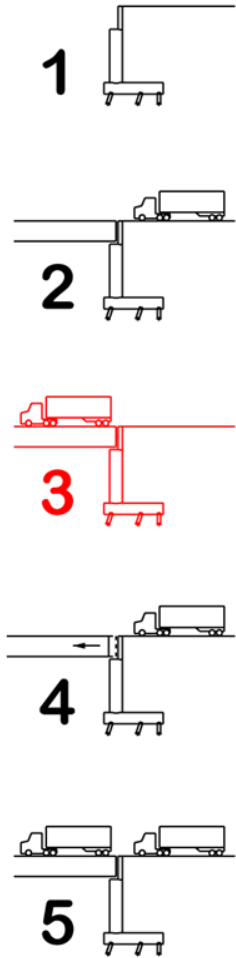

CASE 3 STRENGTH VB

LOAD COMBINATIONS

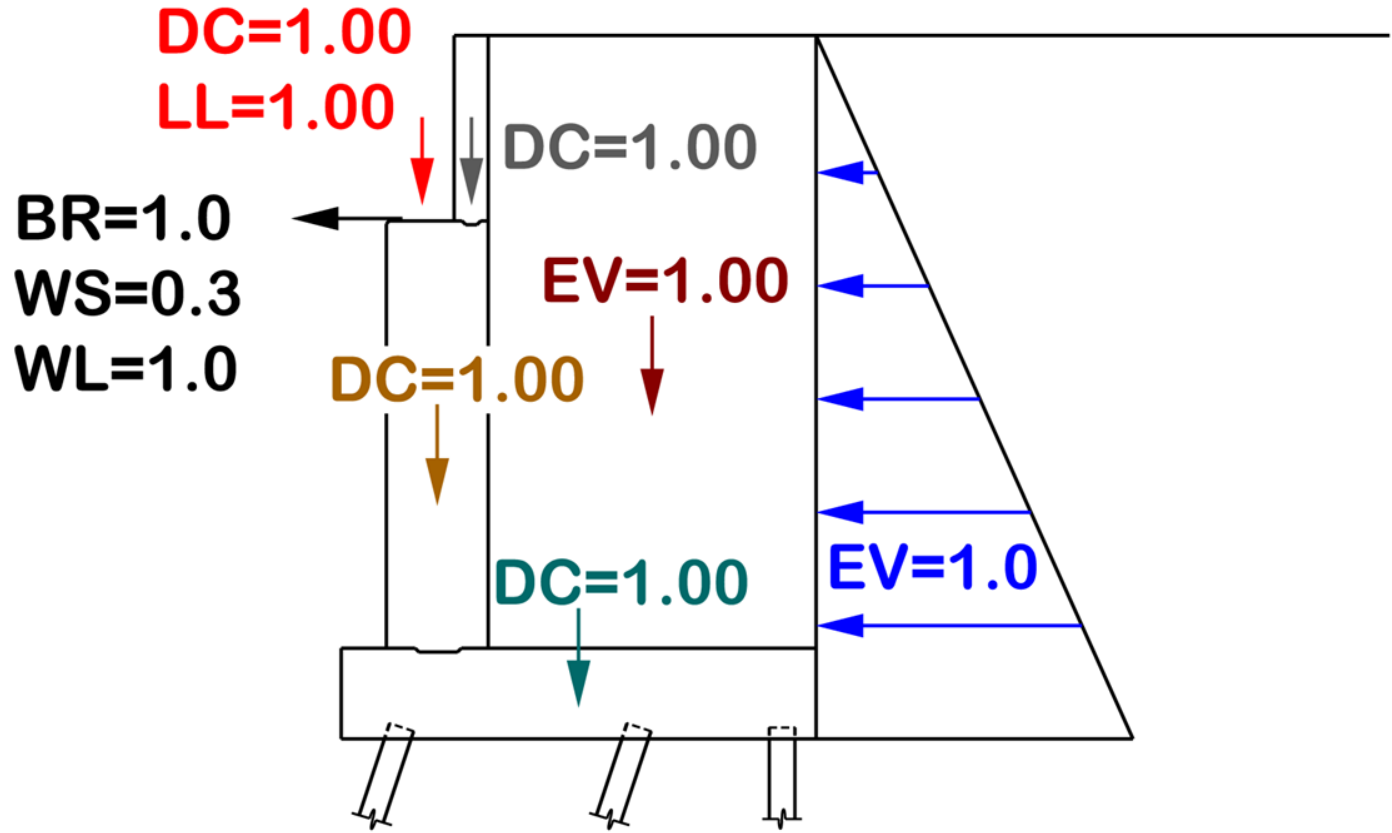
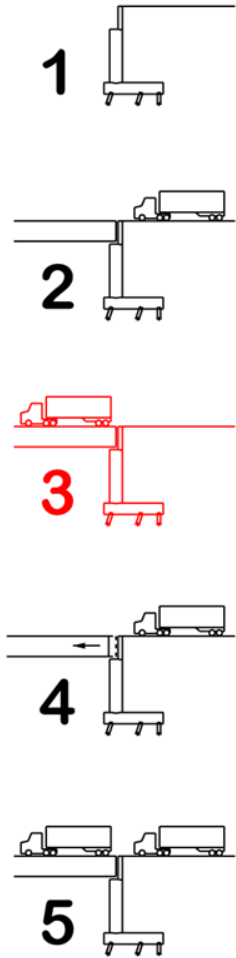

CASE 3 SERVICE I

LOAD COMBINATIONS

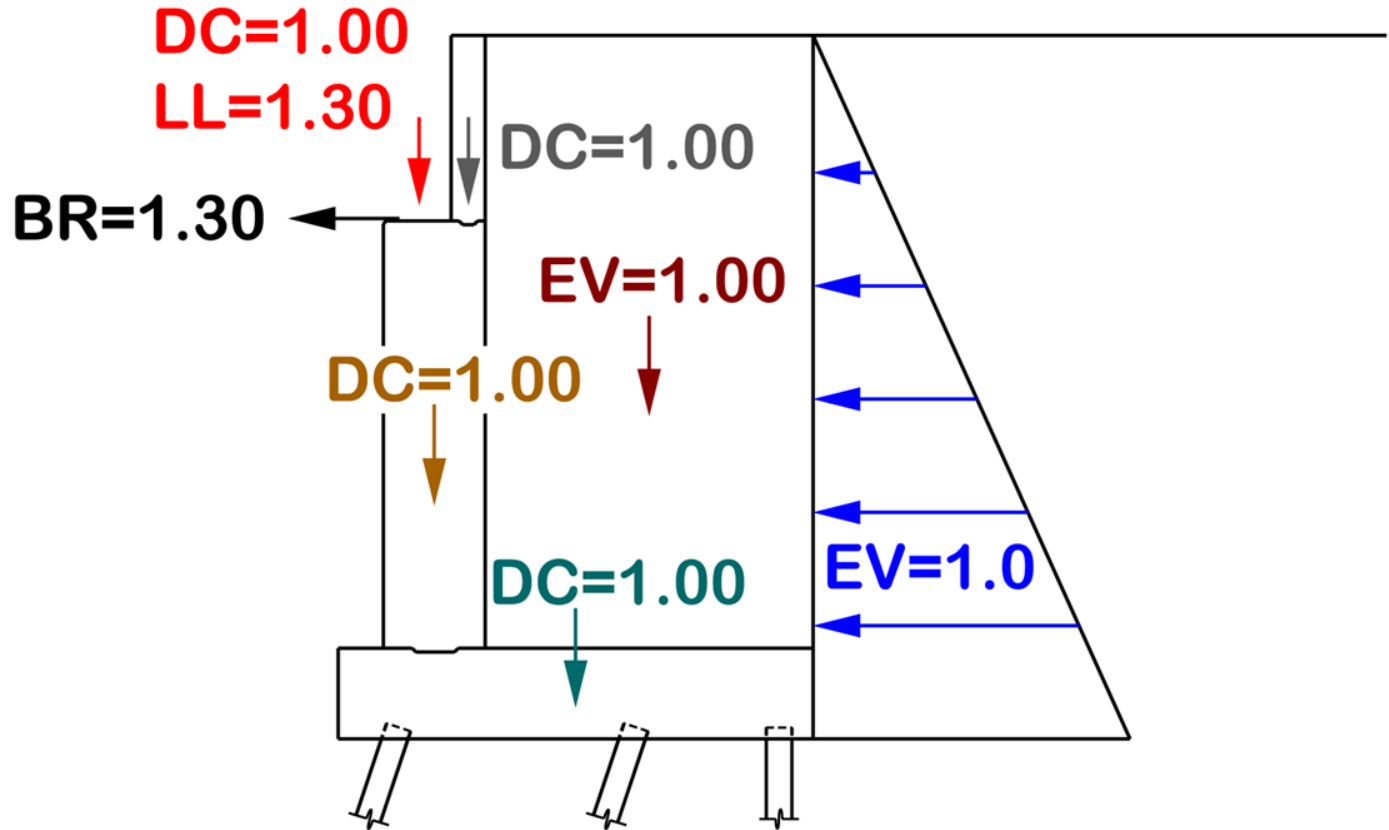
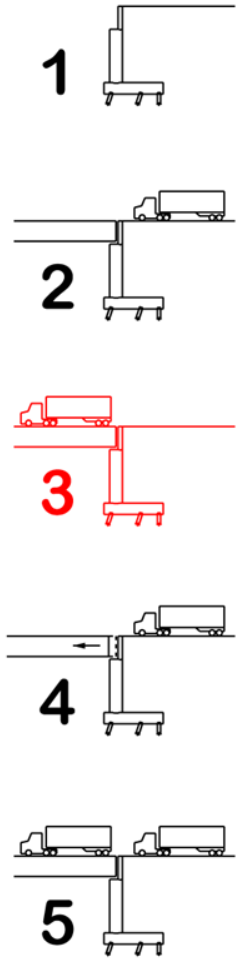

CASE 3 SERVICE II

LOAD COMBINATIONS

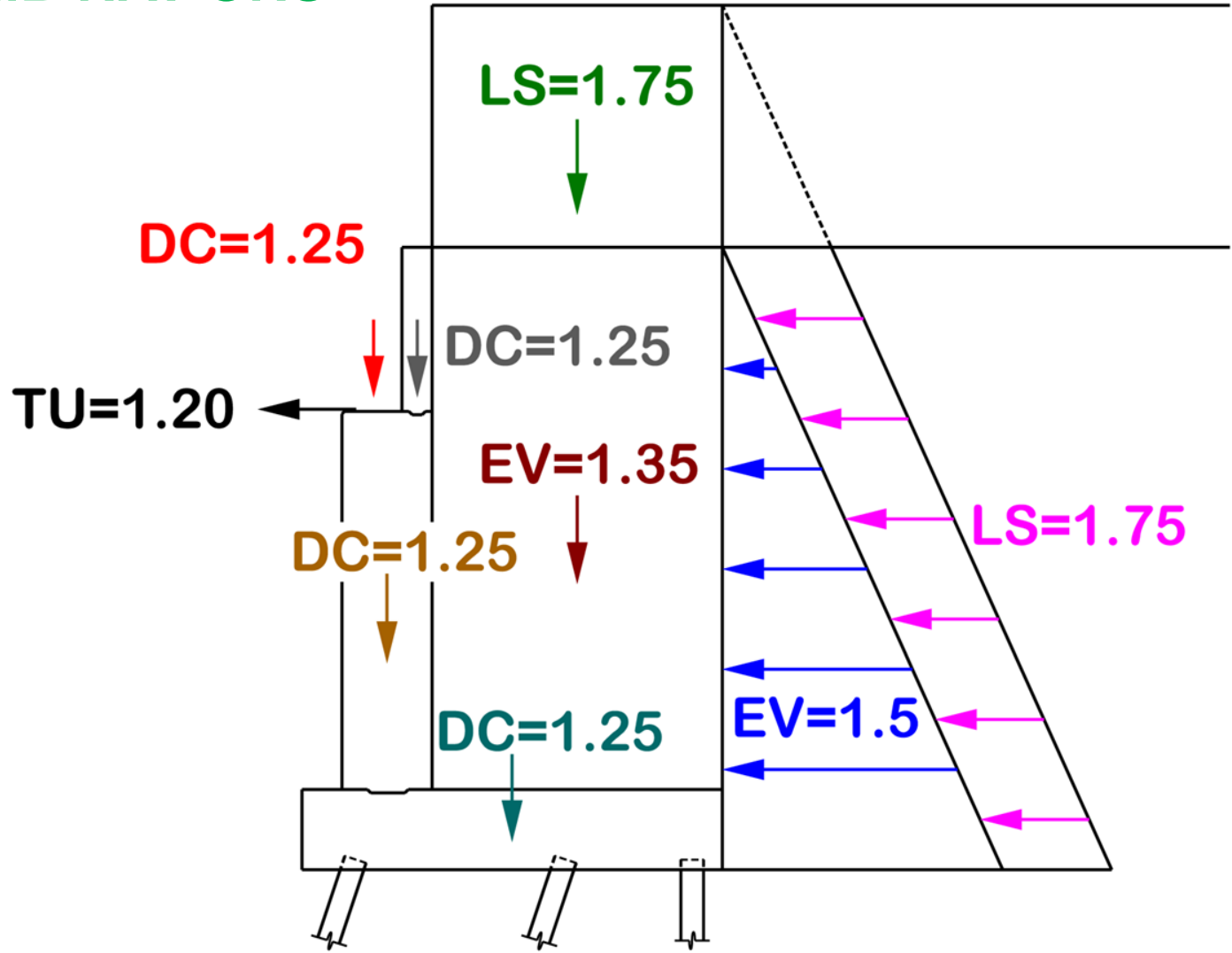
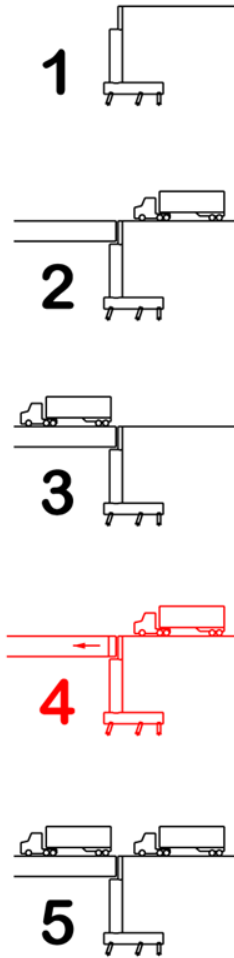

CASE 4 STRENGTH IA

LOAD COMBINATIONS

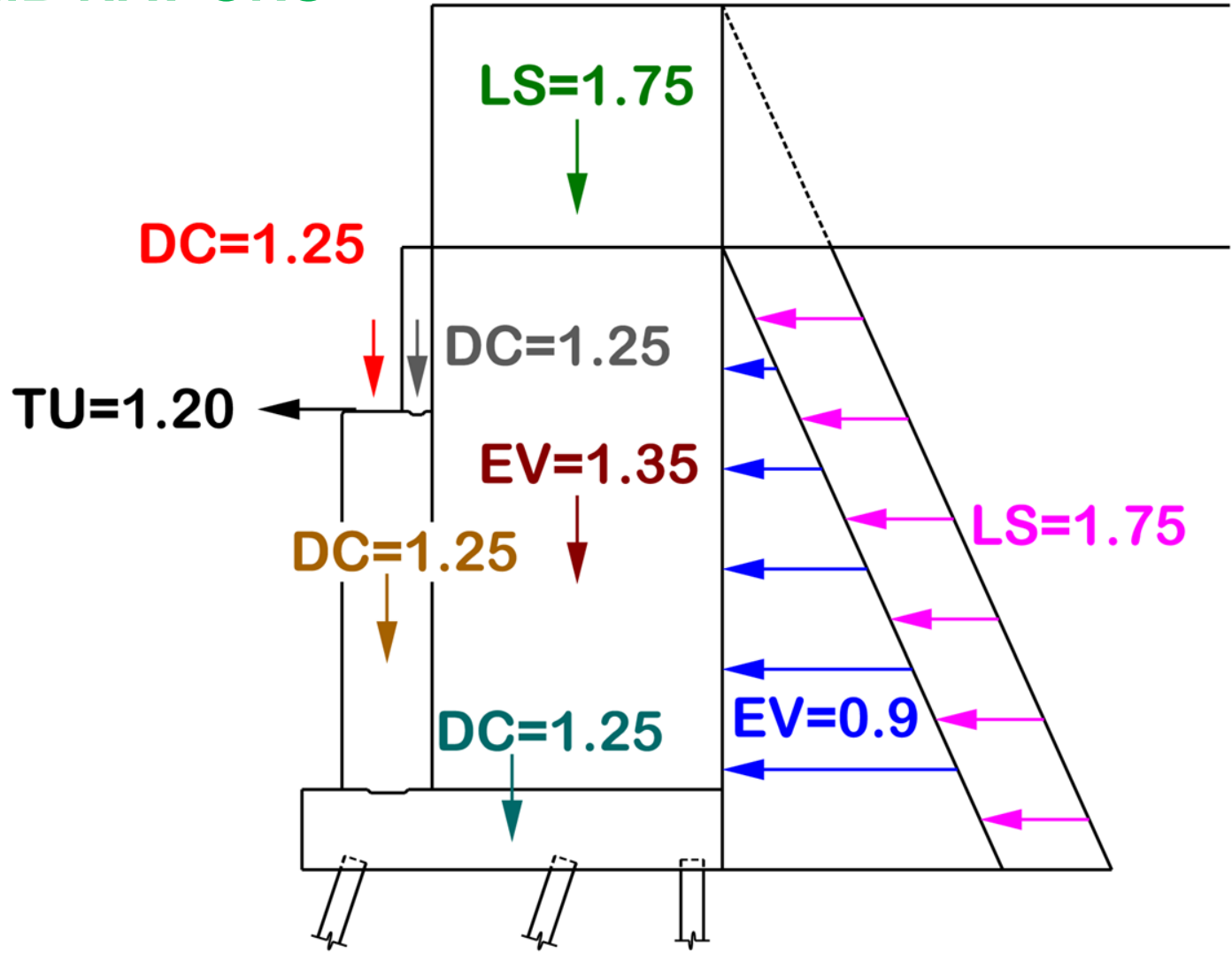
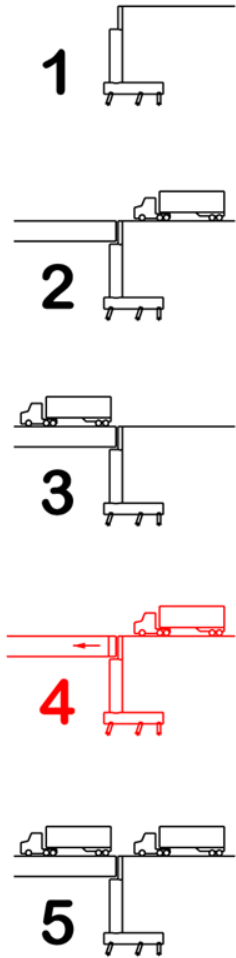

CASE 4 STRENGTH IA2

LOAD COMBINATIONS

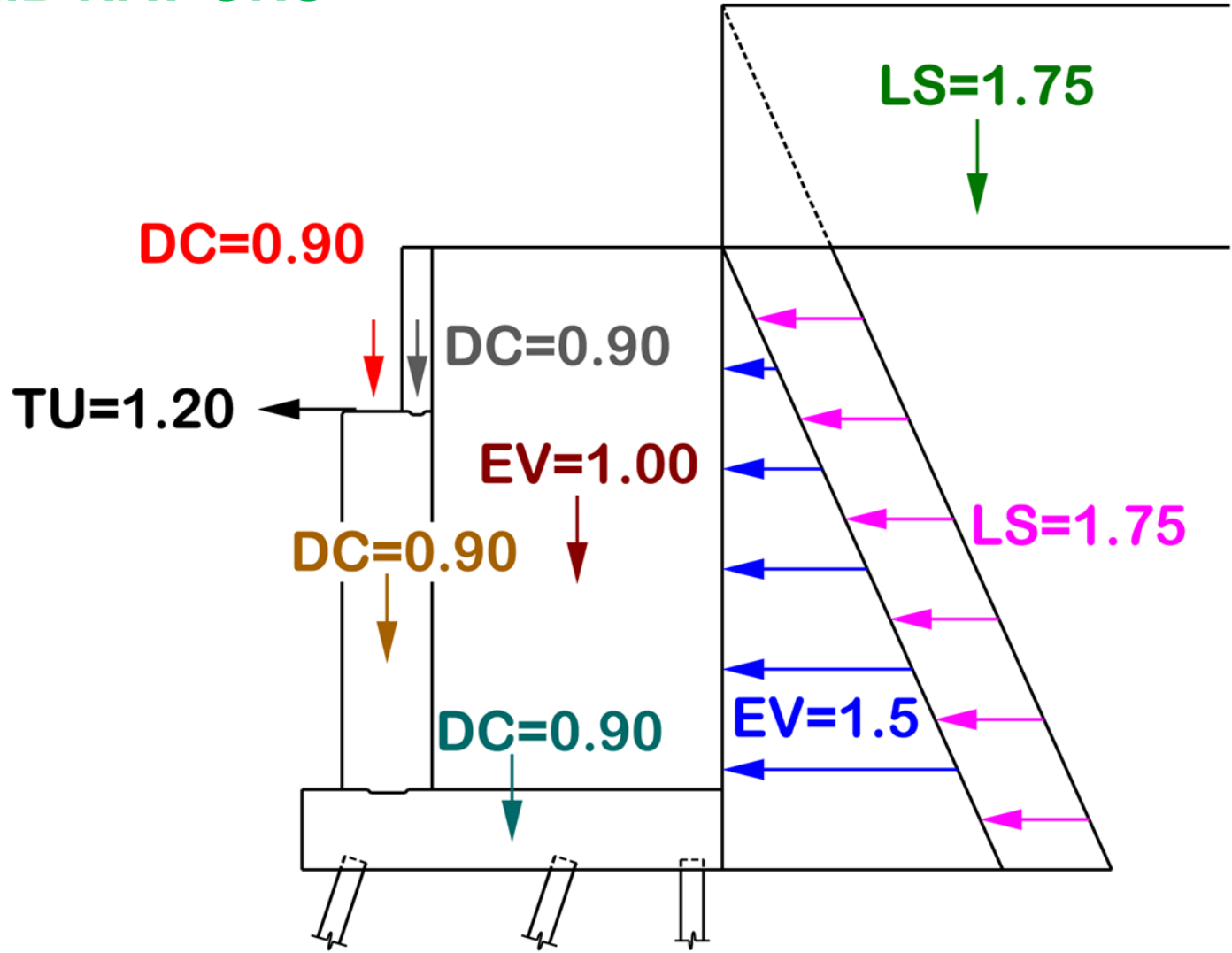
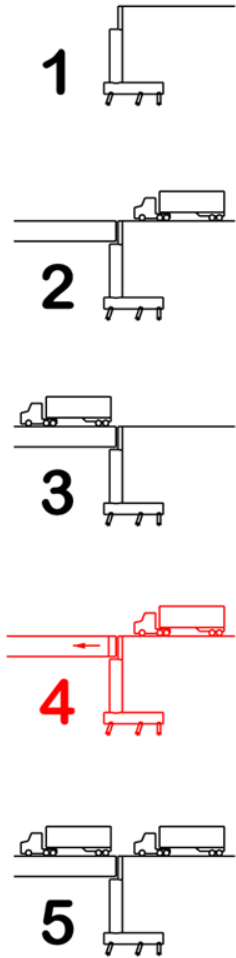

CASE 4 STRENGTH IB

LOAD COMBINATIONS

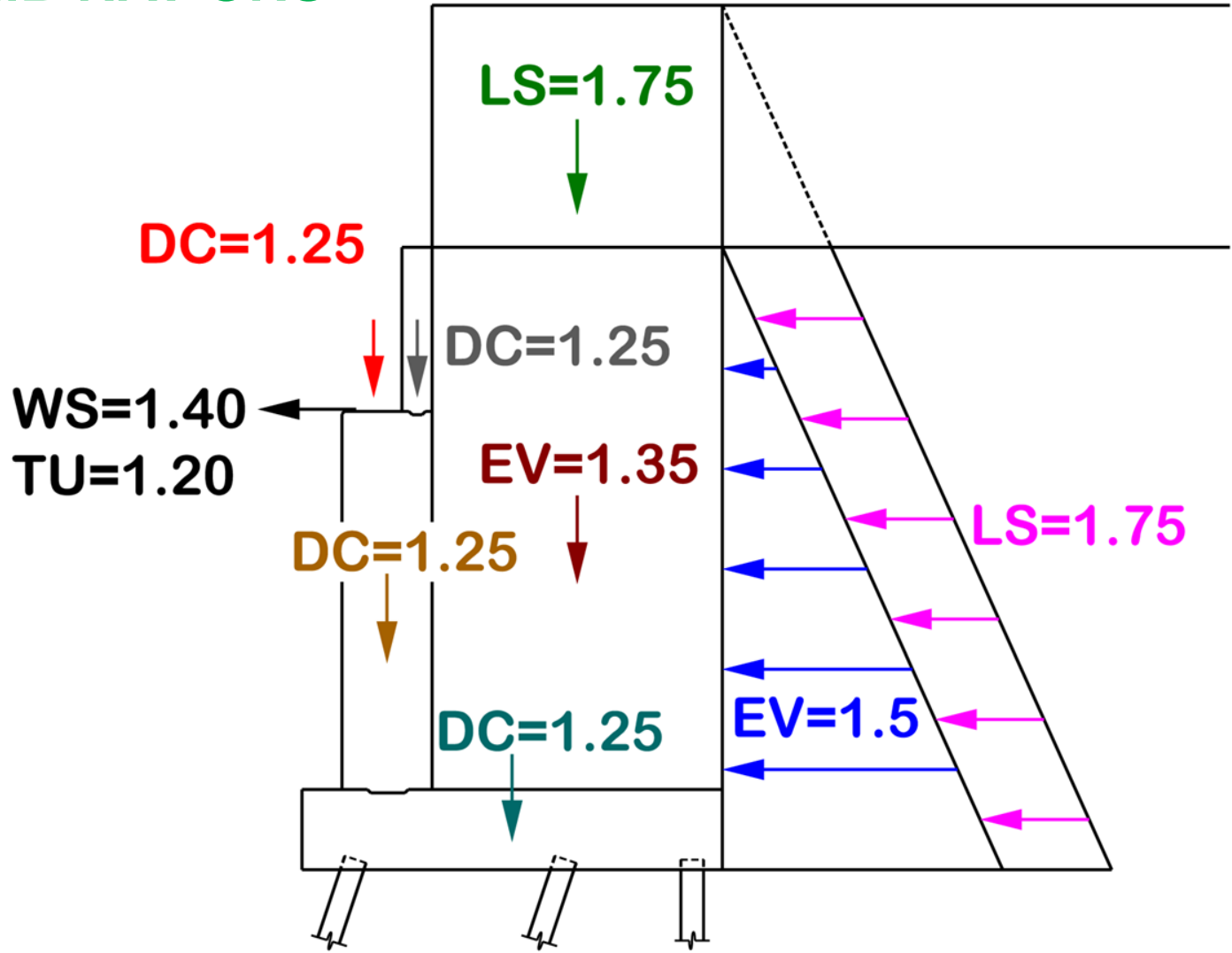
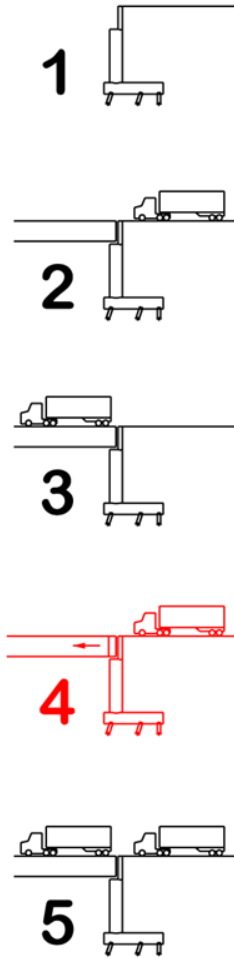

CASE 4 STRENGTH IIIA

LOAD COMBINATIONS

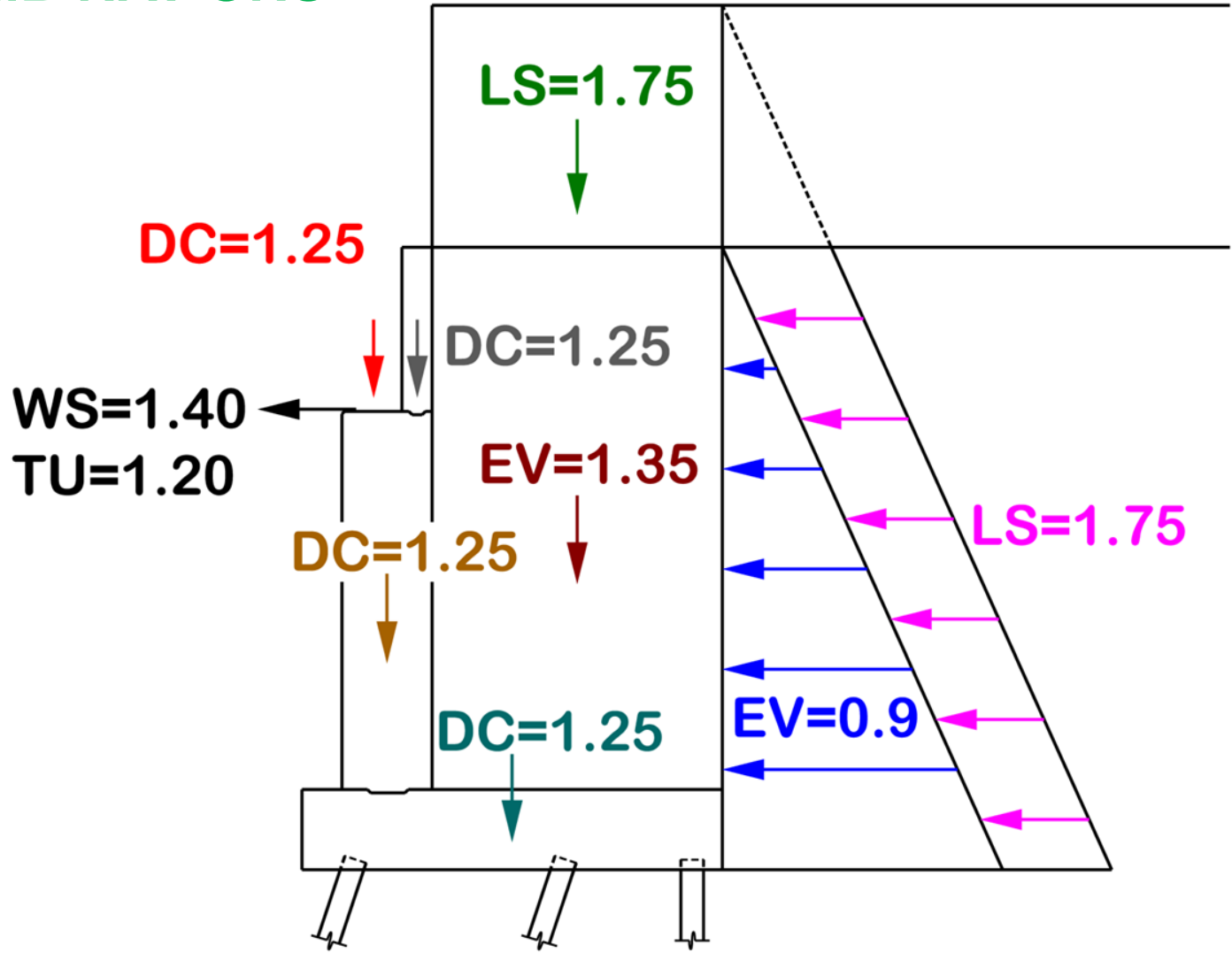
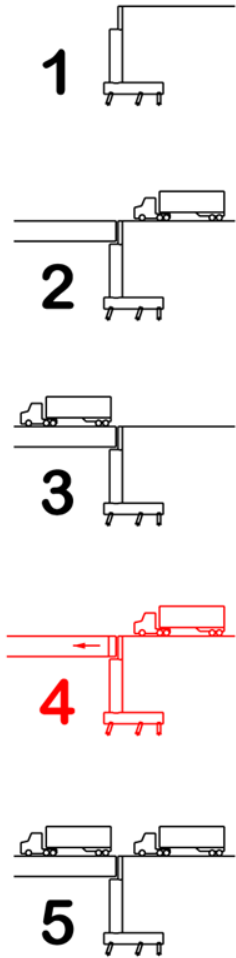

CASE 4 STRENGTH IIIA2

LOAD COMBINATIONS

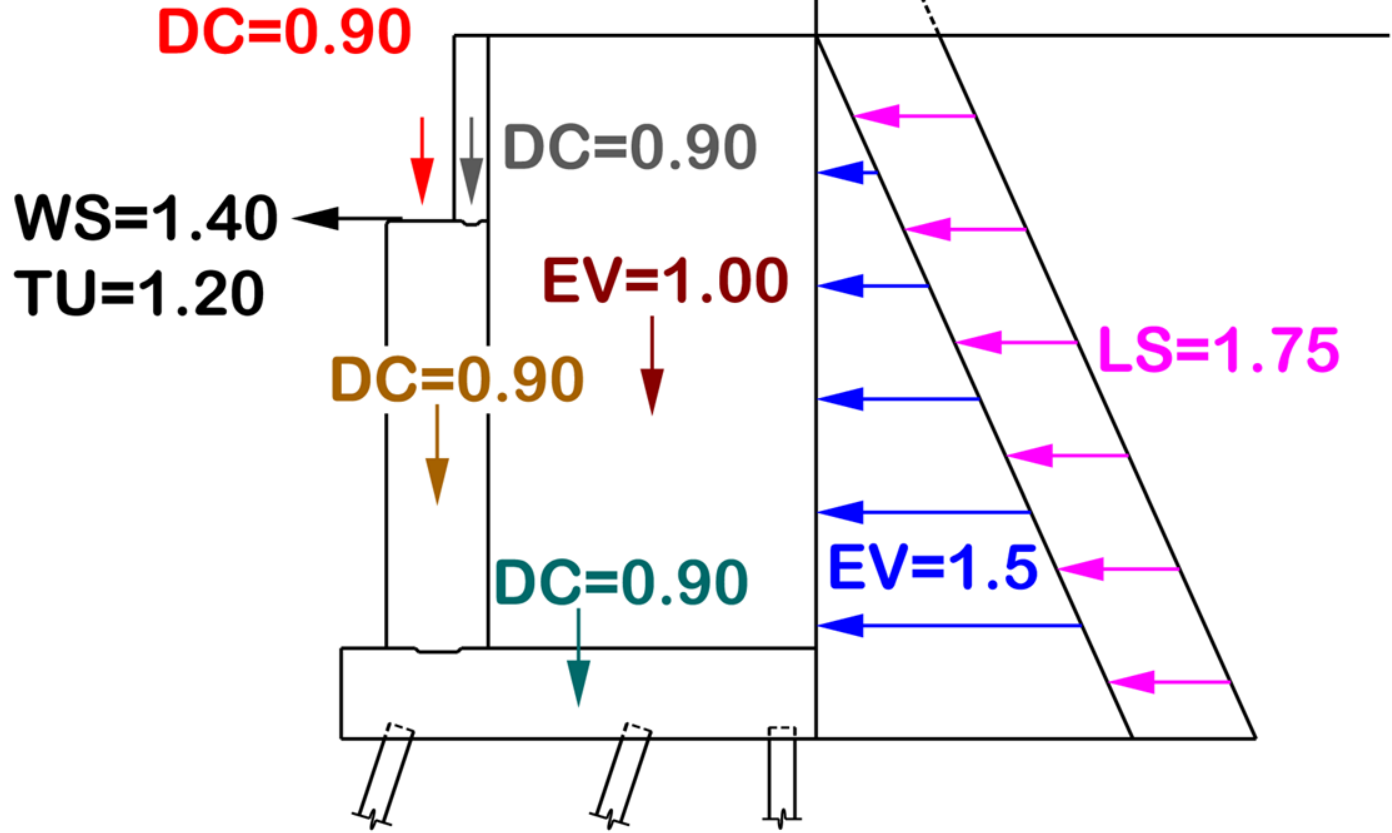
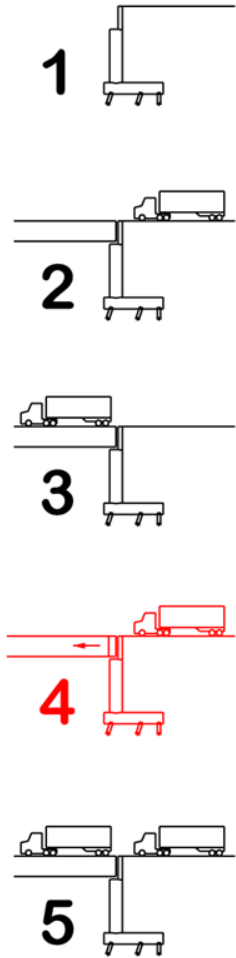

CASE 4 STRENGTH IIIB

LOAD COMBINATIONS

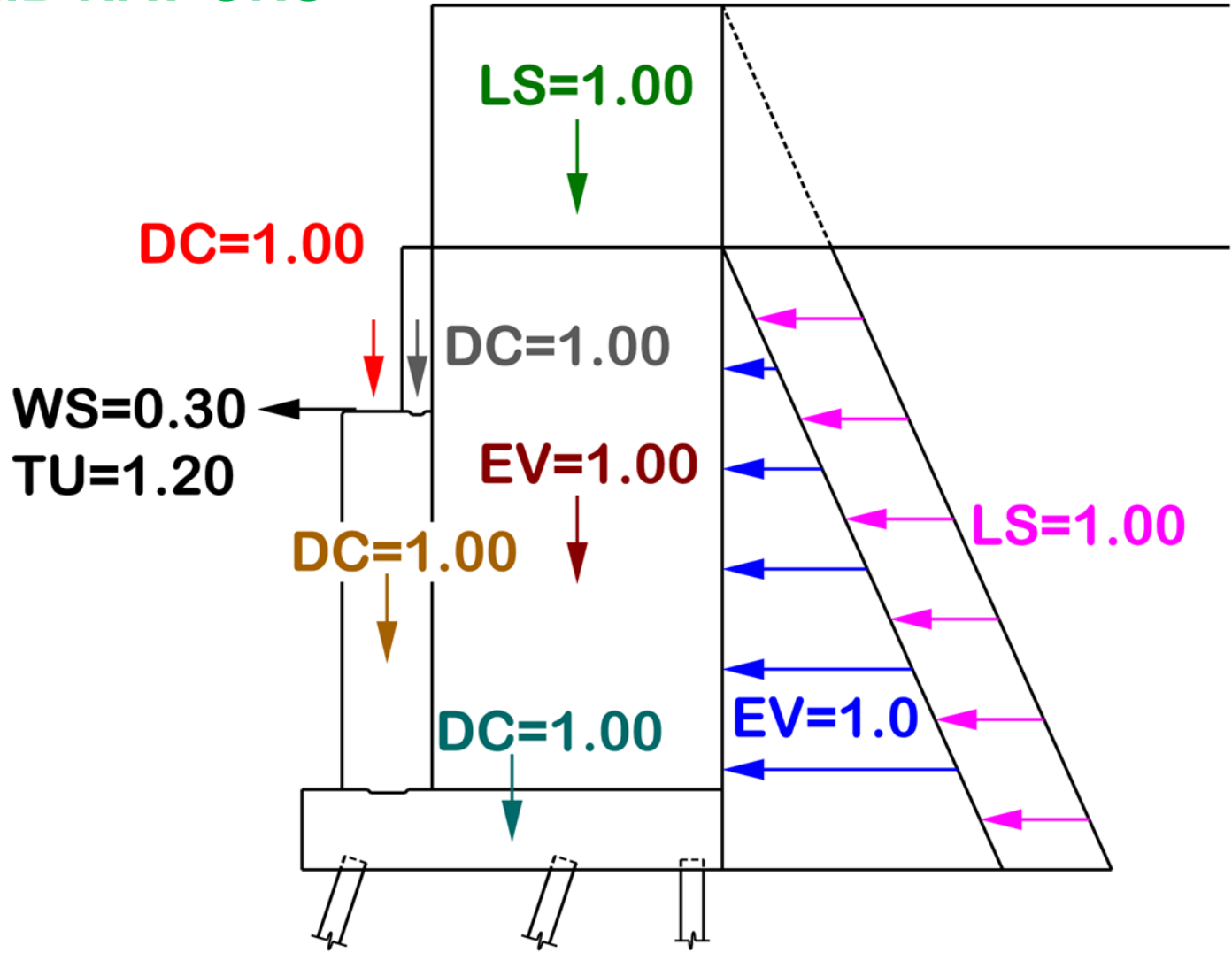
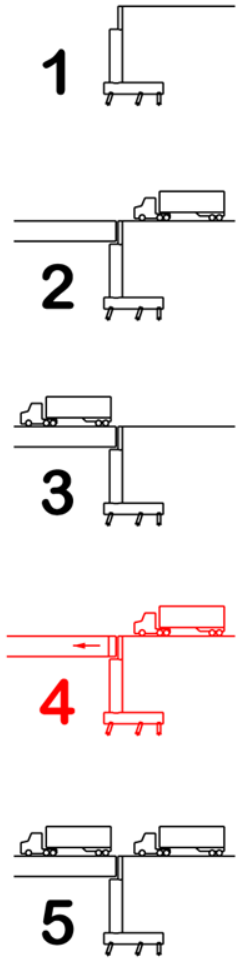

CASE 4 SERVICE I

LOAD COMBINATIONS

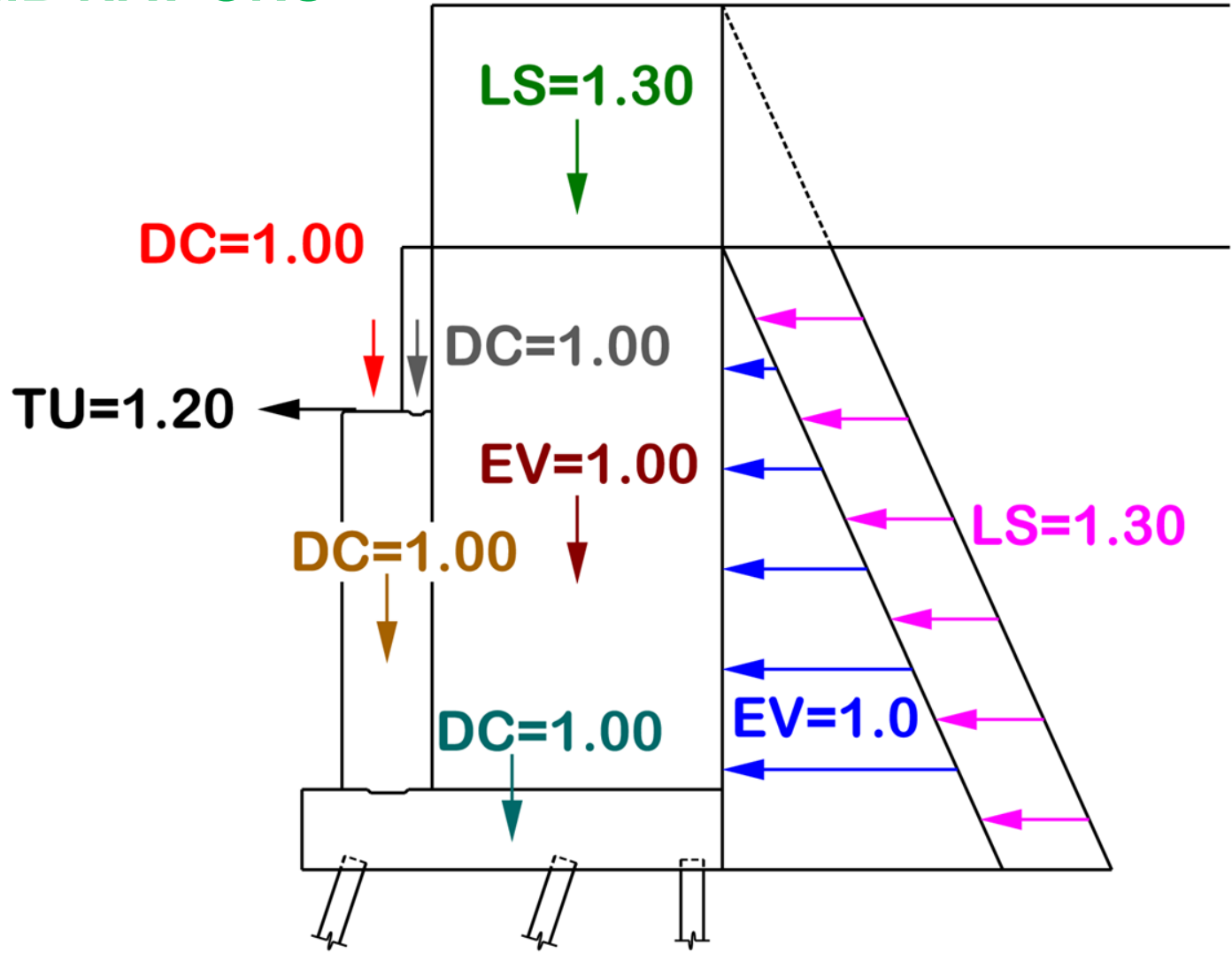
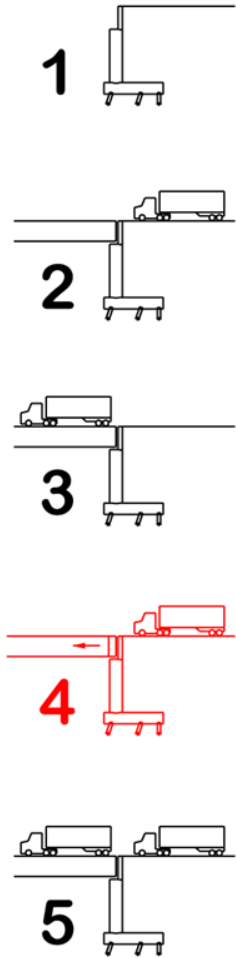

CASE 4 SERVICE II

LOAD COMBINATIONS

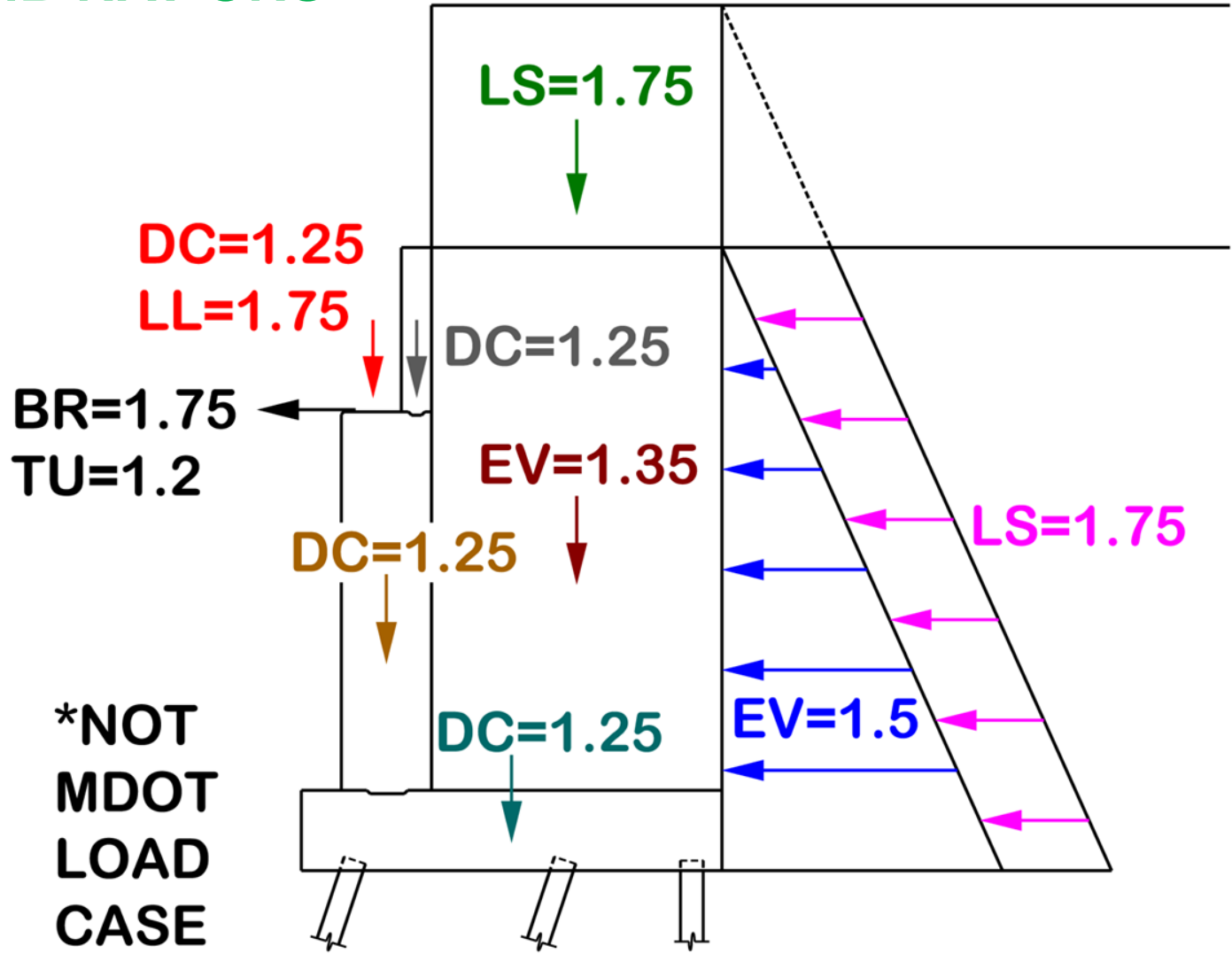
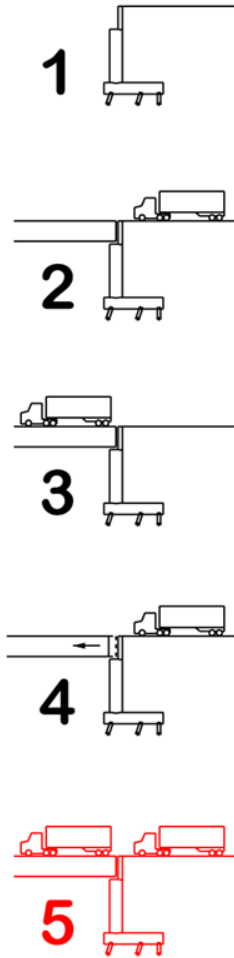

CASE 5 STRENGTH IA*

LOAD COMBINATIONS

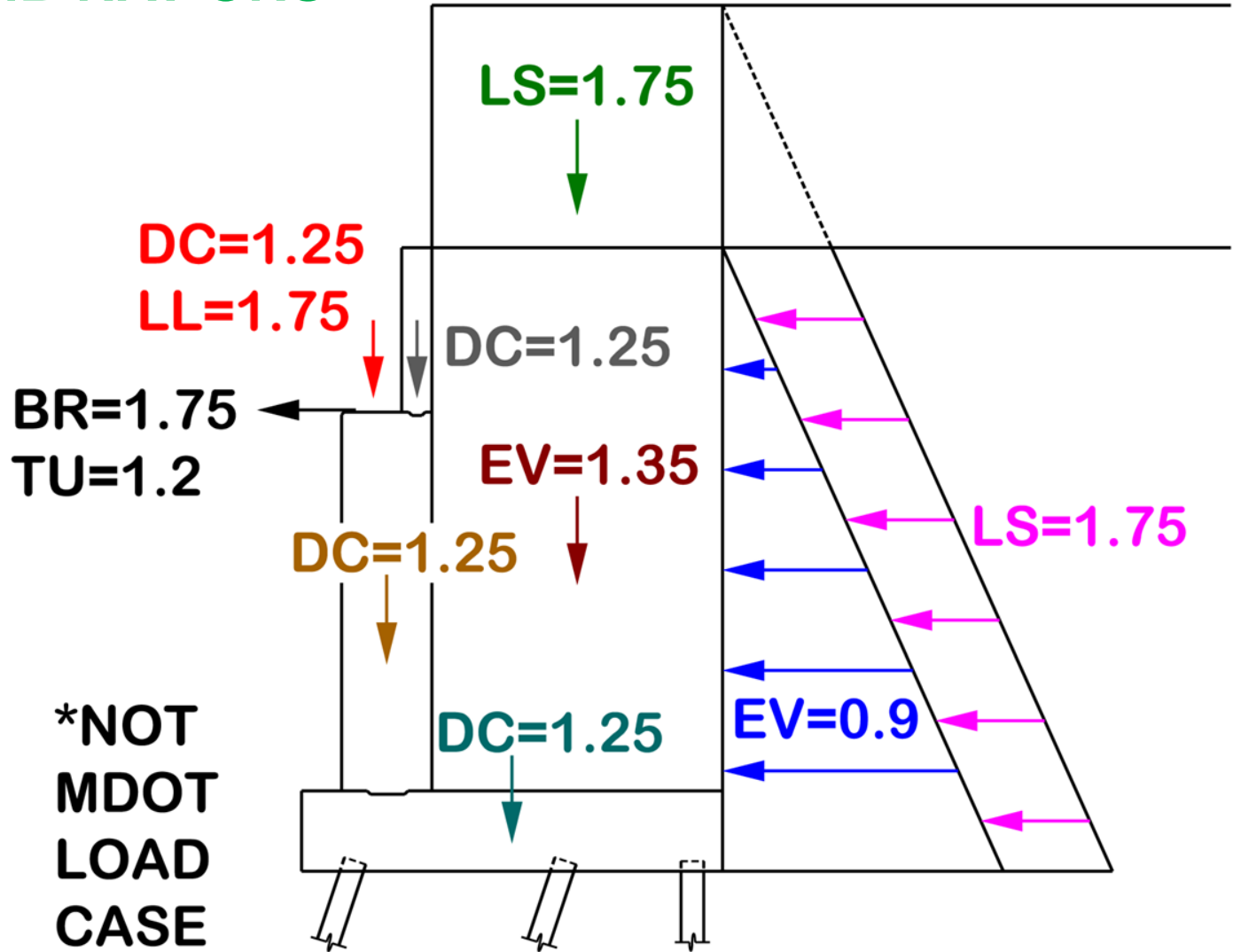
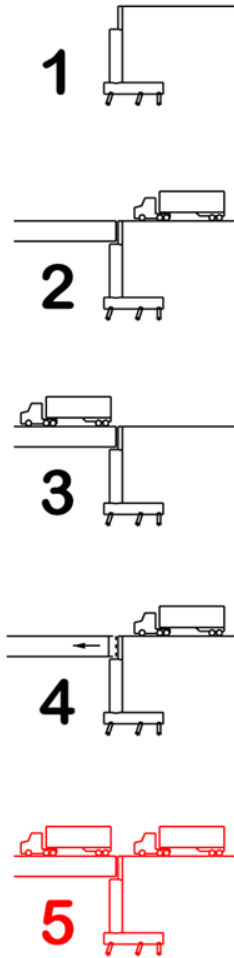

***NOT
MDOT
LOAD
CASE**

CASE 5 STRENGTH IA2*

GEOTECHNICAL AXIAL PILE RESISTANCE

- Geotechnical resistance depends on method of installation
 - MDOT uses $\phi_{\text{dyn}} = 0.50$, while LRFD suggests $\phi_{\text{dyn}} = 0.40$, for piles installed using the FHWA modified Gates Formula (i.e. in accordance with Section 705 of the *MDOT Standard Specifications for Construction*).
 - $\phi_{\text{dyn}} = 0.65$ when using dynamic testing with signal matching (PDA testing) according to the *MDOT Special Provision for Dynamic Pile Testing*.
 - $\phi_{\text{dyn}} = 0.80$ when using one static load testing per zone with dynamic testing with signal matching on at least 2% of production piles.
 - Example: If the driven resistance (R_{ndr}) is equal to 600 kips, then the factored resistance (R_r) is equal to 300 kips using the modified Gates formula.

LATERAL PILE RESISTANCE

- Lateral pile resistance is the result of movement (i.e. pile flexure and interaction with the surrounding soil).
- P-Y method using Lpile to determine lateral resistance. See example to the right.
- Use free-head analysis for typical pile embedment of 6 inches.
- Resistance is based on the amount of tolerable movement.

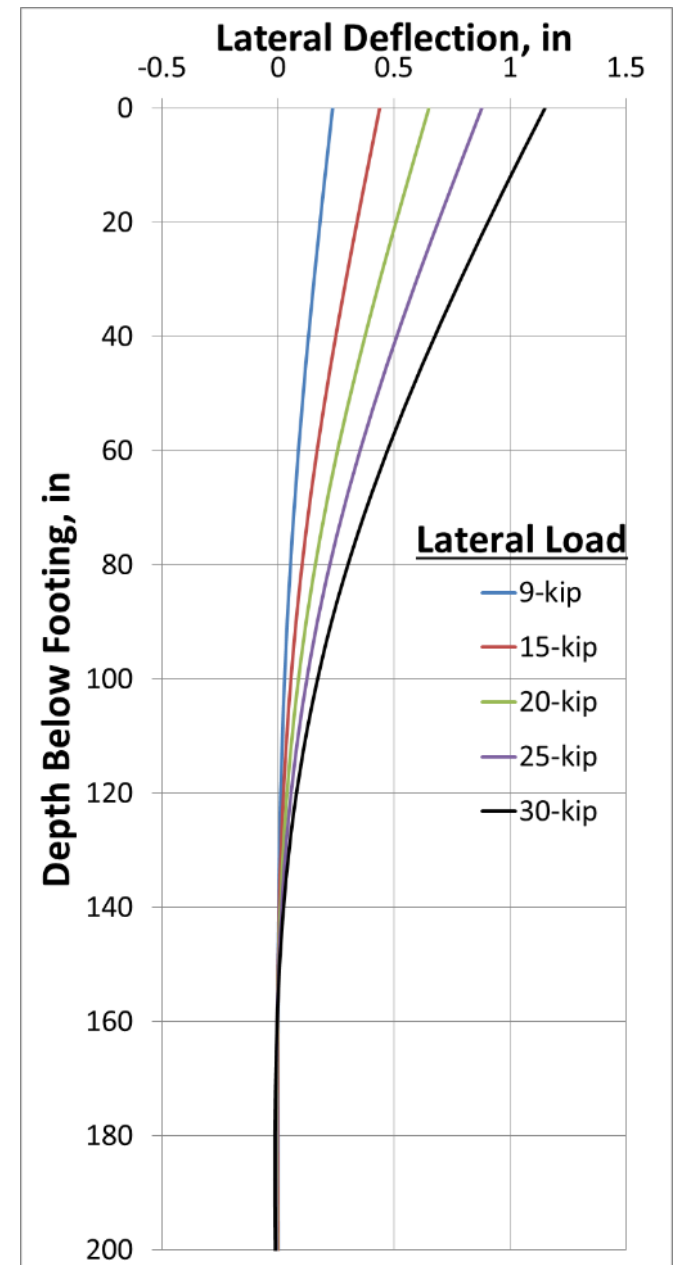

LATERAL PILE RESISTANCE

- Assume ~1.5" movement for Strength Limit States to mobilize resistance*.
- Assume ~1.0" movement for Service Limit States to mobilize resistance*.

**Bridge and Geotechnical Engineer to discuss.*

- Lateral pile resistance is NOT the same as the resistance from the horizontal component of battered piles.
- Usually provided by the geotechnical engineer.
- Must apply pile P-Multipliers (P_m) (LRFD 10.7.2.4).

LATERAL PILE RESISTANCE

Table 10.7.2.4-1—Pile P-Multipliers, P_m , for Multiple Row Shading (averaged from Hannigan et al., 2006)

Pile CTC spacing (in the direction of loading)	P -Multipliers, P_m		
	Row 1	Row 2	Row 3 and higher
$3B$	0.8	0.4	0.3
$5B$	1.0	0.85	0.7

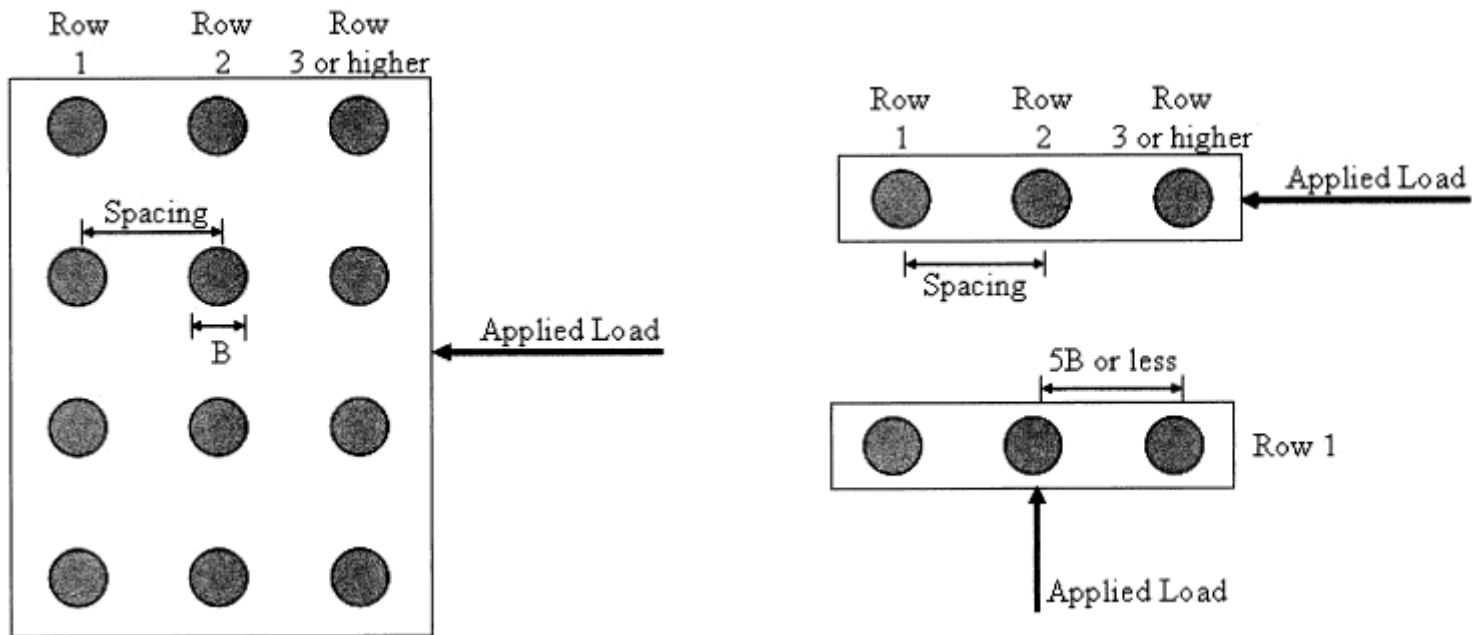

Figure 10.7.2.4-1—Definition of Loading Direction and Spacing for Group Effects

HORIZONTAL RESISTANCE FROM BATTERED PILES

- Is **not** equal to the horizontal component of a piles driven factored resistance (does not satisfy static equilibrium).
- It **is** equal to the horizontal component of the axial reaction on a battered pile (satisfies static equilibrium).

PILE REACTION DETERMINATION

- Assumes footing is rigid for distribution of loads to piles.
- Based on concepts presented in:
 - *Foundation Engineering, 2nd Edition by Peck, Hanson and Thornburn.*
 - *Pile Foundations, 2nd Edition by Chellis.*
 - *Minnesota DOT LRFD Bridge Design Manual.*
- Can be used for 2 or more rows of piles.
- For battered piles, vertical pile reactions determine the resulting horizontal pile reactions, which are used to resist external horizontal loads.
- LRFD provides a method for calculating eccentricity for spread footings.

PILE REACTION DETERMINATION

- The equation for eccentricity (e) can be simplified as:

$$e = \frac{\sum M_{uc}}{\sum V_u}$$

Where:

M_{uc} = Factored moments about point C (i.e. $B/2$)

V_u = Factored vertical loads

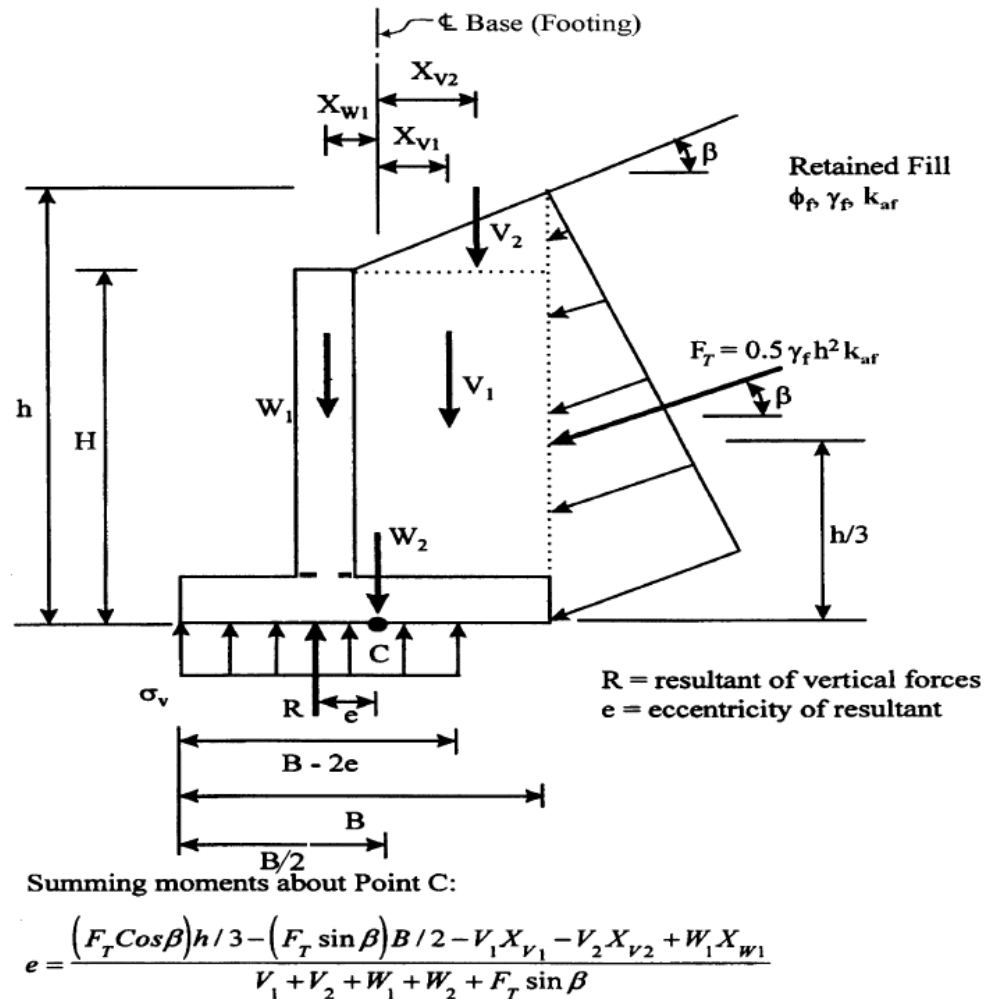

Figure 11.6.3.2-1—Bearing Stress Criteria for Conventional Wall Foundations on Soil

PILE REACTION DETERMINATION

- The eccentricity for a pile supported footing is the difference between the pile group neutral axis and the location of the resultant force.
- Calculate the moment of inertia of the pile group about the neutral axis of the pile group.
- Parallel Axis Theorem $\Sigma I + \Sigma Ad^2$ is the basis for calculating pile reactions.

PILE REACTION DETERMINATION

- The moment of inertia of the pile is insignificant in this calculation. Area changed to the number of piles, so the formula reduces to:

$$\sum N d^2$$

Where: N=Number of piles per foot of wall.

 d=Distance from pile group neutral axis
 to center of individual rows.

PILE REACTION DETERMINATION

- Vertical reaction on piles is calculated using the following basic stress formula:

$$f = \frac{P}{A} + \frac{My}{I}$$

- The formula is modified for piles as follows:

$$R = \frac{V}{N} + \frac{VEd}{I}$$

PILE REACTION DETERMINATION

- Horizontal reaction of battered piles is equal to vertical reaction divided by the batter.
- Must adjust footing size and pile locations until the horizontal resistance (horizontal reaction of battered piles + lateral resistance of all piles) equals or exceeds the applied horizontal forces.
- It is convenient to use a spreadsheet or MathCad to perform these calculations.

PILE REACTION DETERMINATION

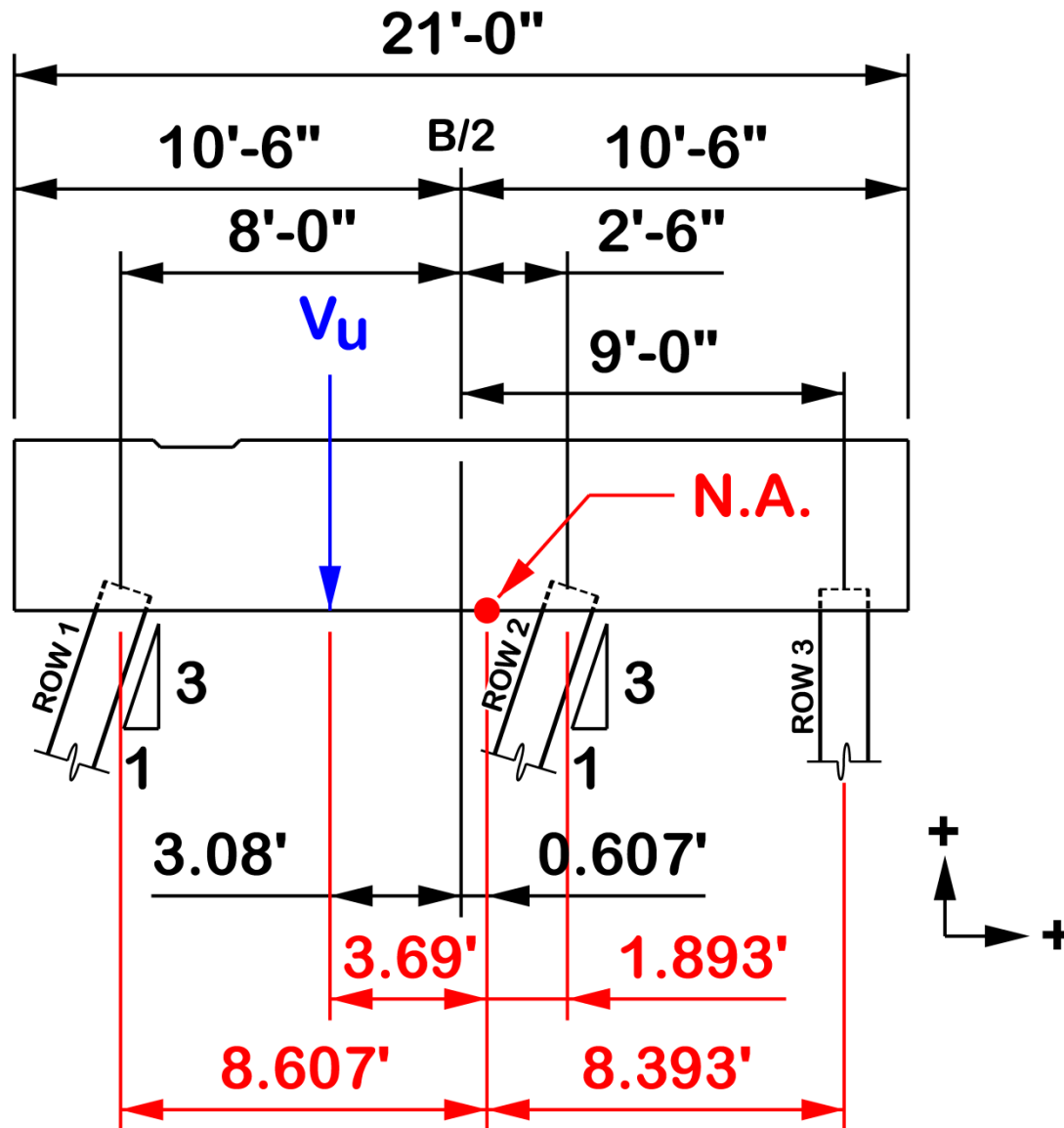

PILE REACTION DETERMINATION

Case 4 Strength IIIA

Driven resistance (Kips)	R_{ndr}	500			
Resistance factor	ϕ	0.75			
Factored axial resistance (Kips)	ϕR_n	375			
		Row 1	Row 2	Row 3	Total
Number of Piles/Foot	N	0.25	0.25	0.2	0.7
Location of Row from B/2	$D_{B/2}$	-8	2.5	9	
$N \cdot D_{B/2}$ (Feet)		-2	0.625	1.8	0.425
$N \cdot D_{B/2 \text{ TOT}} / N_{\text{TOT}}$ - Location of Pile Group Neutral Axis from B/2	D_{NA}	0.607			
Location of Row from Pile Group Neutral Axis (Feet)	d	-8.607	1.893	8.393	
Moment of Inertia = $N \cdot d^2$ (Feet ²)	I	18.5	0.9	14.1	33.5
Summation of factored vertical loads (Kips)	ΣV_u	-116.6			
Summation of factored moments (Kip-Feet)	ΣM_u	358.9			
Summation of factored horizontal forces (Kips)	ΣH_u	-31.6			
Location of Vertical Load from B/2 (Feet)	e	-3.08			
Location of Vertical Load from Pile Group Neutral Axis	E	-3.69			
First term of equation (Kips/Pile)	$\Sigma V_u / N$	-166.6			
Second term of equation (Kips/Pile)	$\Sigma V_u E d / I$	-110.4	24.3	107.6	
Vertical reaction per pile (Kips)	R_v	-277.0	-142.3	-58.9	
Horizontal reaction per pile (Kips)	R_h	-92.3	-47.4	0.0	
Horizontal reaction per pile per foot (Kips)	R_h	-23.1	-11.9	0.0	-34.9
Axial reaction per pile (Kips)	R	291.9	150.0	58.9	All Piles $< \phi R_n$ GOOD
Factored lateral resistance per pile (Kips)		30	25.5	21	
Factored lateral resistance per foot (Kips)		7.5	6.4	4.2	18.1
Factored horizontal resistance per foot (Kips)		30.6	18.2	4.2	53.0 $> \Sigma H_u$ GOOD

COMPARISON BETWEEN EPS AND SAND BACKFILL

75% Increase in Piling

17% Increase in Footing Width

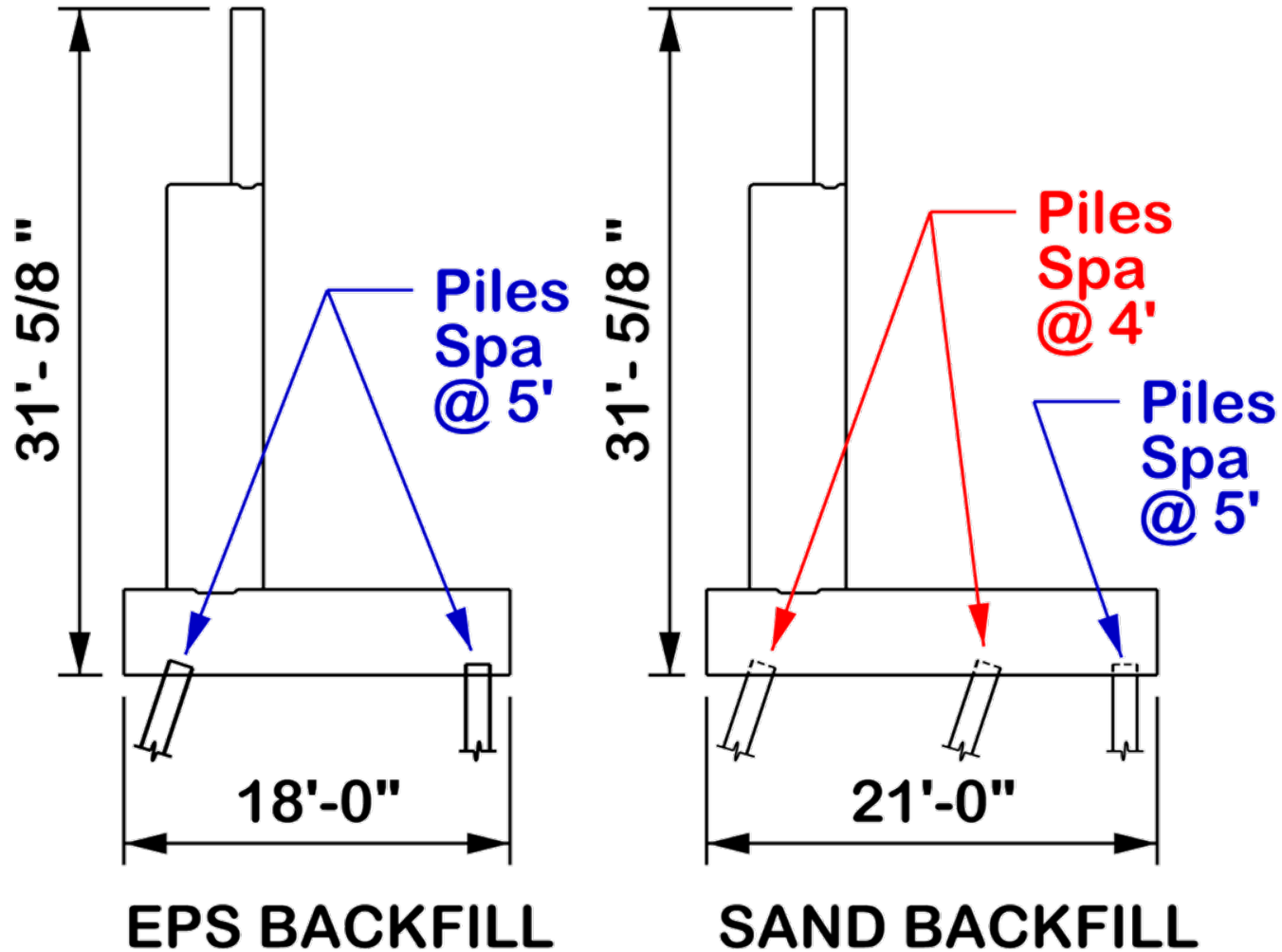

STRUCTURAL DESIGN

- Design flexural reinforcement in walls and footing
 - Crack control checks typically fail in footing due to excessive cover.
 - Maximum moment may not necessarily occur at back face of wall when supported by multiple rows of piles.
- Check shear strength of concrete in walls and footing
 - Typically do not add shear reinforcement.
 - Must check two-way and punching shear in footing.
 - Maximum shear may not necessarily occur at back face of wall when supported by multiple rows of piles.

REFERENCES

- AASHTO LRFD Bridge Design Specifications, 6th Edition
- Michigan DOT Bridge Design Manual
- Minnesota DOT LRFD Bridge Design Manual
 - <http://www.dot.state.mn.us/bridge/lrfd.html>
- Robert Chellis, “Pile Foundations”, 2nd Edition, McGraw-Hill, 1961 (out of print)
- R. Peck, W. Hanson, T. Thornburn, “Foundation Engineering”, 2nd Edition, John Wiley & Sons, 1974
 - <http://www.wiley.com/WileyCDA/WileyTitle/productCd-0471675857.html>

THANK YOU

QUESTIONS?